

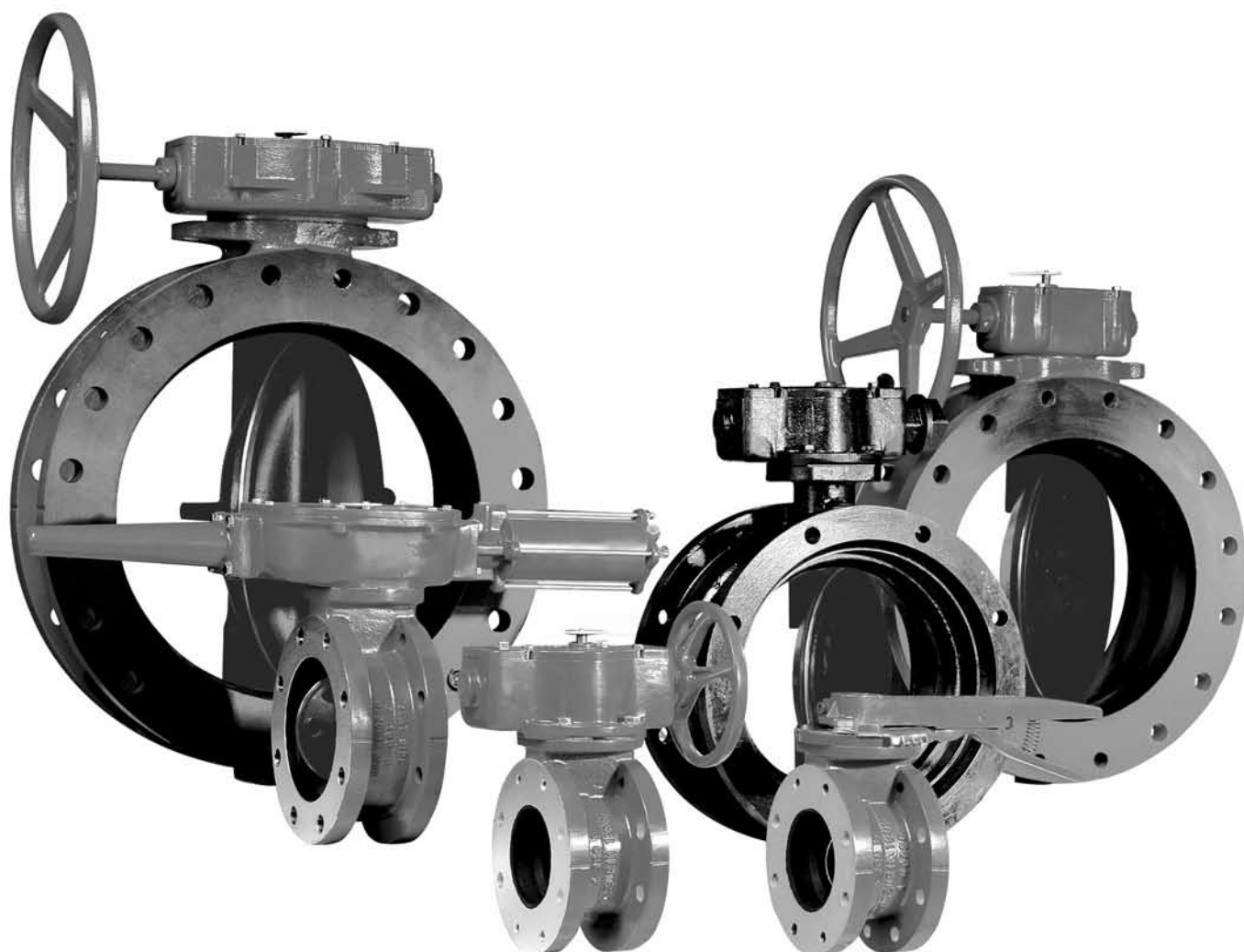

## **AWWA BUTTERFLY VALVES TECHNICAL SPECIFICATIONS**



# Materials of Construction

**3-16" (80-400mm)**

**18 & 20" (450 & 500mm)**

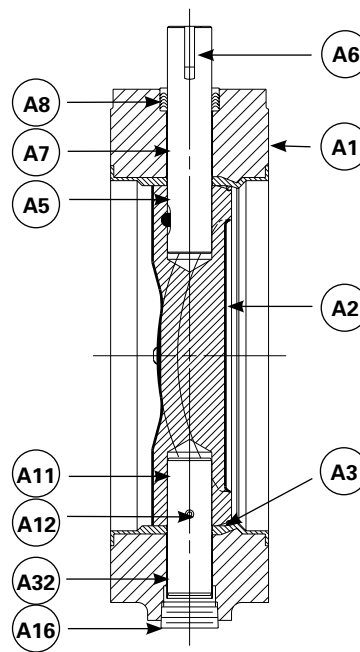
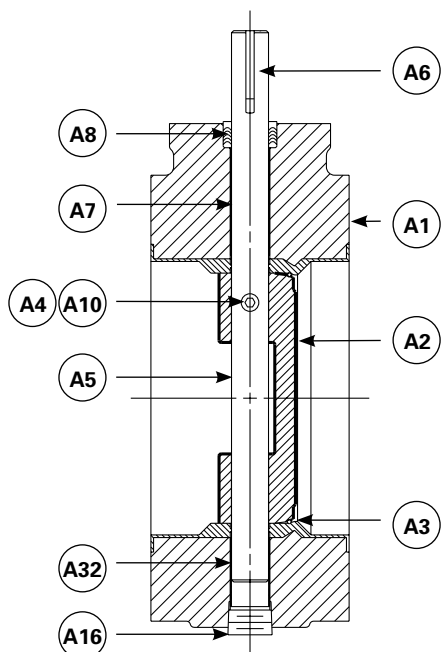

## 3-20" (80-500mm) Valve Sizes

Item	Description	Material
A1	Body NBR or EPDM seat is permanently bonded to the body	Cast Iron ASTM A126 Class B Ductile Iron ASTM A536 Grade 65-45-12
A2	Disc	Cast Iron ASTM A48 Class 40C Ductile Iron ASTM A536 Grade 65-45-12 316 Stainless Steel, ASTM A276, Type CF8M
A3	Disc Seating Edge	316 Stainless Steel, ASTM A276, Type 316
A4	Tangential Pin 14-20" (350-500mm)	316 Stainless Steel, ASTM A276, Type 316 (250B) 17-4 PH Stainless Steel, H1100
A5	Shaft 3-16" (80-400mm) Upper Shaft 18-20" (450-600mm)	304 Stainless Steel, ASTM A276, Type 304 316 Stainless Steel, ASTM A276, Type 316 17-4 PH Stainless Steel, ASTM A564, Type 630 Condition 1150
A6	Key	Steel AISI 1018
A7	Upper Journal Bearing	Nylon and Molybdenum Disulphide Composition (NBR Seat) PTFE (EPDM Seat) (250B) Teflon/Dacron Fabric Liner, Fiberglass back-up shell
A8	Packing	Acrylonitrile Butadiene (NBR Seat) Ethylene Propylene Diene Terpolymer (EPDM Seat)
A10	Torque Screw 3-12" (80-300mm)	316 Stainless Steel, ASTM A276, Type 316 (250B) 17-4 PH Stainless Steel, Condition 1100
A10	Set Screw 14-20" (350-500mm)	18-8 Stainless Steel
A11	Lower Shaft 18-20" (450-600mm)	304 Stainless Steel, ASTM A276, Type 304 316 Stainless Steel, ASTM A276, Type 316 17-4 PH Stainless Steel, ASTM A564, Type 630 Condition 1150
A12	Set Screw 18-20" (450-500mm)	18-8 Stainless Steel
A16	Plug 3-20" (80-500mm)	3-8" (80-200mm) Carbon Steel, SAE J403, Grade 1008/1010 10-20" (250-500mm) Malleable Iron, ASTM A47-52 Grade 35018 (250B, 3-6" (80-150mm)) Carbon Steel, SAE J403, Grade 1008/1010 (250B, 8-20" (200-500mm)) Malleable Iron, ASTM A47-52 Grade 35018
A32	Lower Journal Bearing	Nylon and Molybdenum Disulphide Composition (NBR Seat) PTFE (EPDM Seat) (250B) Teflon/Dacron Fabric Liner, Fiberglass back-up shell

# Materials of Construction

## 24-72" (600-1800mm) Valve Sizes

Item	Description	Material
A1	Body	Cast Iron, ASTM A126 Class B Ductile Iron, ASTM A536 Grade 65-45-12
A2	Seat	Acrylonitrile-Butadiene (NBR) Terpolymer of Ethylene, Propylene and a Diene (EPDM)
A6	Thrust Bearing Cover	Cast Iron, ASTM A126 Class B Ductile Iron, A536 Grade 65-45-12
A7	Screw	18-8 Stainless Steel
A8	O-Ring	Acrylonitrile-Butadiene (NBR) Terpolymer of Ethylene Propylene and a Diene (EPDM)
A9	Thrust Collar	Steel, ASTM 108
A10	Set Screw	18-8 Stainless Steel
A11	Disc	Cast Iron ASTM A48 Class 40C Ductile Iron ATM A536 Grade 65-45-12
A12	Disc Edge	316 Stainless Steel, ASTM A240, Type 316
A13	Disc Pin	24-48" (600-1200mm) 304 Stainless Steel, ASTM A276, Type 304 54-72" (1400-1800mm) 303 Stainless Steel, ASTM 582, Type 303
A14	Nut	18-8 Stainless Steel
A15	Upper Shaft	304 Stainless Steel, ASTM A276, Type 304 316 Stainless Steel, ASTM A276, Type 316 17-4 PH Stainless Steel, ASTM, Type 630 Condition 1150
A16	Key	Steel AISI 1018
A17	Bearing	Teflon/Dacron Fabric Liner, Fiberglass back-up shell
A19	Packing	NBR Acrylonitrile-Butadiene (NBR Seat) EPDM Ethylene Propylene and a Diene (EPDM Seat)
A20	Spacer 30-48" (750-1200mm)	316 Stainless Steel, ASTM A276, Type 316
A22	Gland 60-72" (1500-1800mm)	Bronze ASTM B-62
A23	Screw (Used with A22)	18-8 Stainless Steel
A24	Washer (Used with A22)	18-8 Stainless Steel
A25	Lower Shaft	304 Stainless Steel, ASTM A276, Type 304 316 Stainless Steel, ASTM A276, Type 316 17-4 PH Stainless Steel, ASTM, Type 630 Condition 1150
A26	Adjusting Screw	303 Stainless Steel, ASTM A582, Type 303
A27	Jam Nut	18-8 Stainless Steel
A29	Thrust Plate	Carbon Steel AISI A108
A30	Screw 24-48" (600-1200mm)	18-8 Stainless Steel
A31	Lockwasher 24-48" (600-1200mm)	18-8 Stainless Steel
A32	Epoxy	Epoxy
A33	O-Ring	Acrylonitrile-Butadiene (NBR) Terpolymer of Ethylene Propylene and a Diene (EPDM)

Contact DeZURIK for materials of construction on valve sizes 78-120" (2000-3000mm).

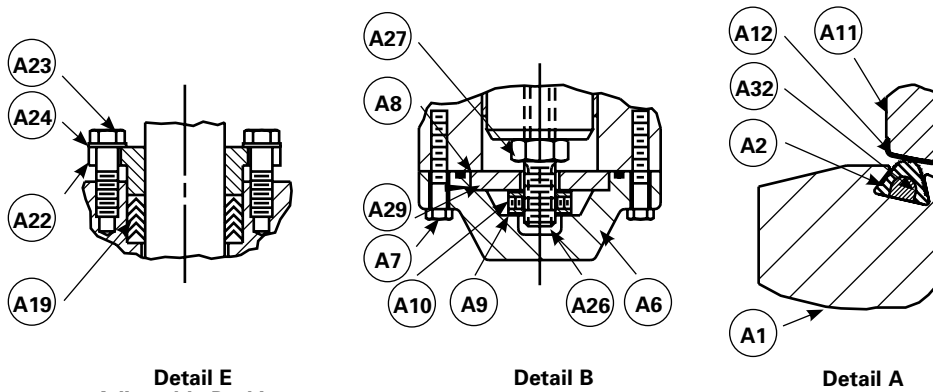

**Detail E**  
Adjustable Packing  
Optional on 24-48" (600-1200mm)  
Standard on 54-72" (1400-1800mm)

**Detail B**

**Detail A**

## 24-42" (600-1100mm)

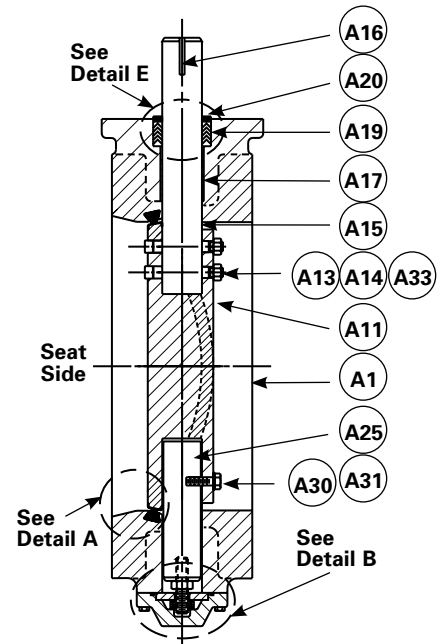

## 48-72" (1200-1800mm)

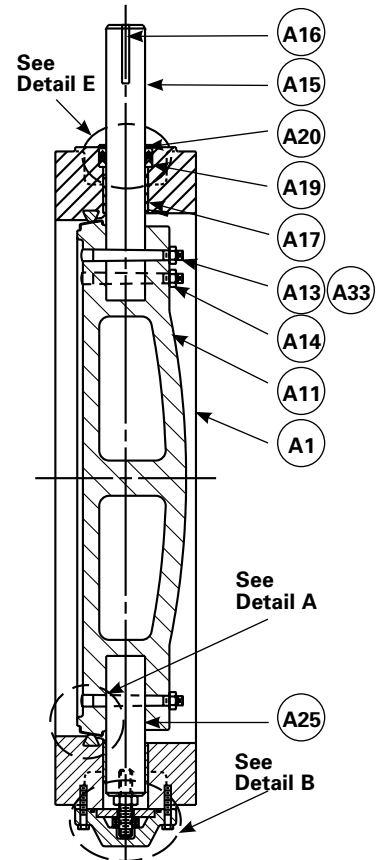

# Cv/Kv Values

## Class 150B

Valve Size	100% Cv/Kv	
	Flat Cv/Kv	Dome Cv/Kv
3" 80mm	362 313	356 308
4" 100mm	658 569	646 559
6" 150mm	1,380 1,194	1,360 1,176
8" 200mm	2,440 2,111	2,390 2,067
10" 250mm	3,910 3,382	3,840 3,322
12" 300mm	5,730 4,960	5,630 4,870
14" 350mm	7,840 6,782	7,700 6,661
16" 400mm	10,200 8,823	9,980 8,633
18" 450mm	12,600 10,899	12,400 10,726
20" 500mm	15,800 13,667	15,500 13,408
24" 600mm	22,900 19,809	22,500 19,463

## Class 25A, 75B, 150B

Valve Size	100% Cv/Kv	
	Flat Cv/Kv	Dome Cv/Kv
30" 750mm	36,500 31,573	35,900 31,054
36" 900mm	53,200 40,018	52,300 45,240
42" 1100mm	73,100 63,232	71,800 62,107
48" 1200mm	109,000 94,285	103,000 89,095
54" 1400mm	140,000 121,100	131,000 113,315
60" 1500mm	173,000 149,645	163,000 140,995
66" 1700mm	210,000 181,650	198,000 171,270
72" 1800mm	250,000 216,250	236,000 204,140

## % Open vs. % Cv/Kv 3-42" (80-1100mm)

% Open	Flat % Cv/Kv	Dome % Cv/Kv
10	3	3
15	4	4
20	6	5
25	8	7
30	10	9
35	12	11
40	15	14
45	19	18
50	23	22
55	28	27
60	35	34
65	42	41
70	49	49
75	55	58
80	61	66
85	69	75
90	79	87
95	91	98
100	100	100

## 48-72" (1200-1800mm)

% Open	Flat % Cv/Kv	Dome % Cv/Kv
10	1	2
15	2	2
20	4	3
25	5	4
30	6	6
35	7	8
40	9	10
45	13	14
50	15	18
55	18	22
60	23	27
65	28	33
70	35	41
75	44	48
80	55	59
85	67	71
90	79	84
95	96	96
100	100	100

Contact DeZURIK for Cv/Kv Values on 78-120" (2000-3000mm) valves and for Class 250B.

# Applicable Standards

### DeZURIK AWWA valves are in conformance with the industry standards listed below.

Valves conform to AWWA Standard ANSI/AWWA C-504, Rubber-Seated Butterfly Valves.

Dimensions and drilling of flanged end connections conform to Class 125 sections of ASME/ANSI B16.1, Cast Iron Pipe Flanges and Flanged Fittings.

Mechanical-Joint bell dimensions conform to ANSI/AWWA C111/A21.11, Rubber Gasket Joints for Ductile Iron and Gray Iron Pressure Pipe and Fittings.

Bonding of 3" (80mm) through 20" (600mm) seat conforms to ASTM D429, Standard Test Methods for Rubber Property — Adhesion to Rigid Substrates.

Ozone resistance of seat material conforms to ASTM D1149, Standard Test Method for Rubber Deterioration — Surface Ozone Cracking in a Chamber.

Seat material volume increase is less than 2% after immersion in distilled water for 70 hours, when tested in accordance with ASTM D471, Standard Test Method for Rubber Property — Effect of Liquids.

Materials conform to standards as listed in the Materials of Construction.

# Ordering Information

## Valve Style

**BAW = AWWA Butterfly Valve**

### Valve Size

3"	(80mm)	42"	(1100mm)
4"	(100mm)	48"	(1200mm)
6"	(150mm)	54"	(1400mm)
8"	(200mm)	60"	(1500mm)
10"	(250mm)	66"	(1700mm)
12"	(300mm)	72"	(1800mm)
14"	(350mm)	78"	(2000mm)
16"	(400mm)	84"	(2100mm)
18"	(450mm)	90"	(2300mm)
20"	(500mm)	96"	(2400mm)
24"	(600mm)	102"	(2600mm)
28"	(700mm)	108"	(2700mm)
30"	(750mm)	114"	(2900mm)
36"	(900mm)	120"	(3000mm)

**Note:** All orders for 28" (700mm) and larger must include valve pipeline mounting position and shaft orientation as second line information.

### End Connection

F1	=	ANSI 125 Flanged 3-120"	(80-3000mm)
F2	=	ANSI 250 Flanged 3-48"	(80-1200mm)
MJ	=	Mechanical Joint 4-48"	(100-1200mm)

With Mechanical joint ends, buriable actuators are recommended.

### Body Material

#### CI = Cast Iron

F1	=	3-72"	(80-1800mm)	(Standard) Class 25A, 75B, 150B	78-120"	(2000-3000mm)	On Application
MJ	=	4-48"	(100-1200mm)	Class 150B	(Standard)		

#### DI = Ductile Iron

F1	=	3-72"	(80-1800mm)	(Standard Option) Class 25A, 75B, 150B, 250B	78-120"	(2000-3000mm)	On Application
F2	=	3-54"	(80-1400mm)	(Standard Option) Class 250B	60-120"	(1500-3000mm)	On Application
MJ	=	4-48"	(100-1200mm)	Class 150B (Standard Option)	Class 250B	(Standard)	

### Packing/Seat Combination

#### Packing Material

NBRN	=	Acrylonitrile-Butadiene Self-Adjusting	(-20 to 180°F)(-29 to 82°C)	3-72"	(80-1800mm); 78-120"	(2000-3000mm)	On Application
NBRA	=	Acrylonitrile-Butadiene Adjustable	(-20 to 180°F)(-29 to 82°C)	Do not use with buried service.			
				3-72"	(80-1800mm); 78-120"	(2000-3000mm)	On Application
EPDN	=	EPDM Self-Adjusting	(-20 to 290°F)(-29 to 143°C)	3-24"	(80-600mm); 30-120"	(750-3000mm)	On Application
EPDA	=	EPDM Adjustable	(-20 to 290°F)(-29 to 143°C)	Do not use with buried service.			
				3-24"	(80-600mm); 30-120"	(750-3000mm)	On Application
TCN	=	PTFE Self-Adjusting	(-20 to 450°F)(-29 to 232°C)	30-72"	(750-1800mm)		
TCA	=	PTFE Adjustable	(-20 to 450°F)(-29 to 232°C)	Do not use with buried service.			
				30-72"	(750-1800mm)		

#### Seat Material

NBR	=	Acrylonitrile-Butadiene	(-20 to 180°F)(-29 to 82°C)	(Must use NBRN or NBRA packing.)			
EPDM	=	Terpolymer of Ethylene Propylene & a Diene	(-20 to 290°F)(-29 to 143°C)	(Must use EPDA or EPDN, TCN or TCA packing.)			

### Class AWWA C-504

25A	=	28-48"	(700-1200mm)	flanged
75B	=	28-120"	(700-3000mm)	flanged
150B	=	3-120"	(80-3000mm)	flanged
		4-48"	(100-1200mm)	mechanical joint
250B	=	3-120"	(80-3000mm)	flanged
		4-48"	(100-1200mm)	mechanical joint

### Disc/Shaft Combination

#### Disc Material

CI	=	Cast Iron disc with 316 stainless steel edge	Class 150B 3-20"	(80-500mm)
DI	=	Ductile Iron disc with 316 stainless steel edge	Class 25A 28-48"	(700-1200mm)
			Class 75B 28-72"	(700-1800mm)
			Class 150B 3-72"	(80-1800mm);
			78-120"	(2000-3000mm)
			Class 250B 3-54"	(80-1400mm)
			Class 250B 60-120"	(1500-3000mm)
S2	=	316 stainless steel	Class 150B 3-42"	(80-1100mm)
			Class 150B 54-120"	(1400-3000mm)

#### Shaft Material

S1	=	304 stainless steel shaft	(Standard)	
S2	=	316 stainless steel shaft	(Standard Option)	
S5	=	17-4 PH stainless steel shaft	Class 250B 3-54"	(80-1400mm)
			All others on application.	

### Options

ARRA	=	Conforms to: American Recovery and Reinvestment Act of 2009, Buy American, Section 1605, Use of American Iron, Steel and Manufactured Goods
TB	=	Standard Certified Hydrostatic Shell Test and Bi-Directional Seat Leak Test. Stainless Steel bolting on valve.

### Ordering Example:

BAW,24,F1,CI,NBRN-NBR,150B,DI-S1\* Actuator

# M-Series Manual Actuator

## Handwheel

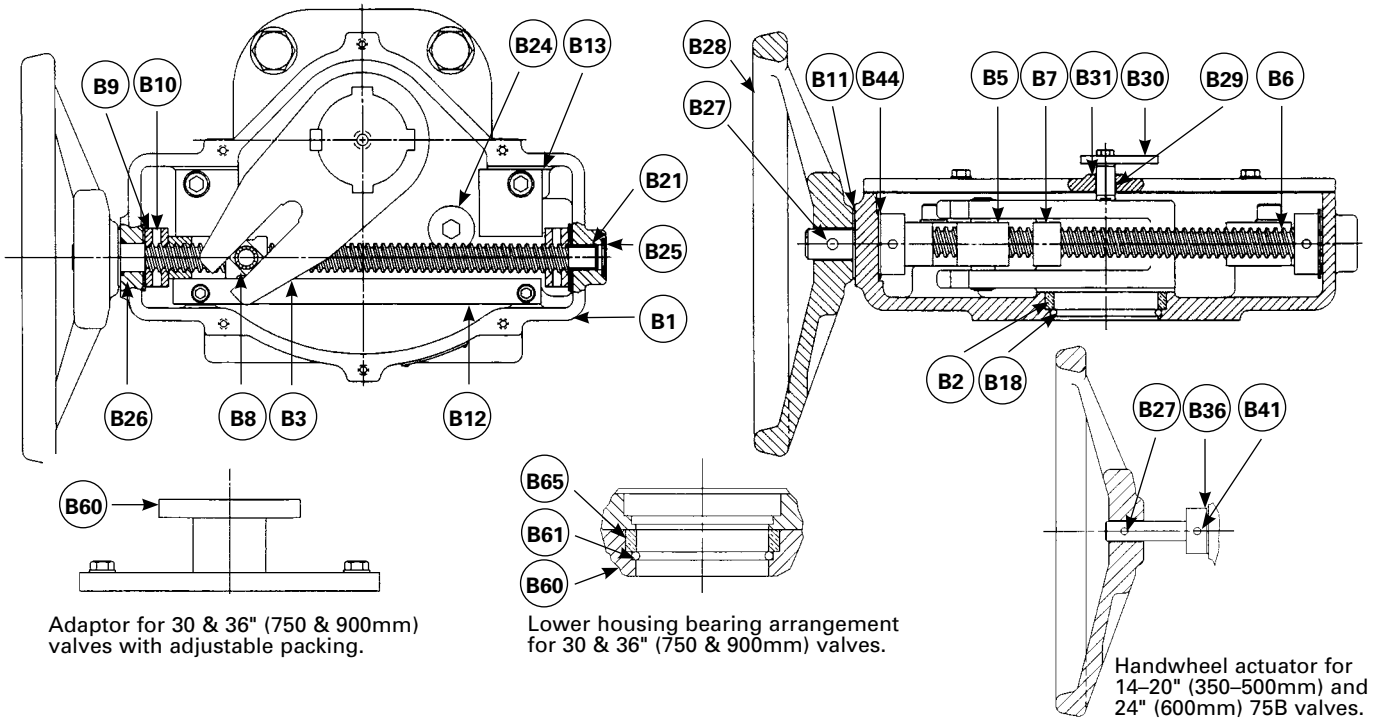

### M-Series Manual Actuator Materials of Construction

Item	Description	Material
B1	Housing	Cast Iron, ASTM A126 Class B
B2	Bearing (Housing)	Bronze Oil Impregnated
B3	Yoke	Ductile Iron, ASTM A536 80-55-06
B5	Yoke Nut Assembly	Ductile Iron, ASTM A536 80-55-06
B6	Shaft	Steel, ASTM A29 1144
B7	Stop Nut	Steel, AISI 1018
B8	Bearing	Sintered Stainless Steel
B9	Collar	Steel, AISI 1215
B10	Pin	Chrome Steel, Type 420
B11	Thrust Washer	Bronze Oil Impregnated
B12	Yoke Guide	Steel, AISI 1018
B13	Guide Block (450 ft. lb. Actuator only)	Steel, AISI 1018
B18	O-Ring	Nitrile
B21	Bearing	Bronze Oil Impregnated
B24	Screw (M-7 Actuator only)	Zinc Plated Steel
B25	Expansion Plug	Zinc Plated Steel
B26	O-Ring	Nitrile
B27	Pin	Zinc Plated Steel
B28	Handwheel	Cast Iron, ASTM A126 Class B
B29	Driver	Stainless Steel, 316L
B30	Pointer	Steel 14 Gauge
B31	Seal	Steel with Nitrile
B34	Wrenching Square	Cast Iron, ASTM A126 Class B

Item	Description	Material
B35	Collar	Steel, AISI 1215
B36	Chainwheel	Cast Iron, ASTM A126 Class B
B38	Chain Guide	Cast Iron, ASTM A126 Class B
B40	Link Closing	Steel Zinc Plated
B41	Pin	Steel Zinc Plated
B44	Thrust Washer	Fiberglass with Steel Zinc Plated Back (M-7 Actuator)
B45	Collar	Steel, AISI 1215
B46	Bearing	Bronze Oil Impregnated
B47	Set Screw	Steel Zinc Plated
B48	Washer	Steel Zinc Plated
B49	Ring Retainer	Steel
B50	Adaptor A36 12-20" (300-500mm) Valves	Steel Hot Rolled
B51	Seal 12-20" (300-500mm) Valves	Carbon Steel, Nitrile
B55	Bearing (Adaptor Plate)	Bronze Oil Impregnated
B57	Gasket	Fiber Non-Asbestos
B60	Adaptor 30 & 36" (750 & 900mm)	Steel, ASTM A36
B61	O-Ring 30 & 36" (750 & 900mm)	Nitrile (NBR)
B62	Shaft Extension	Steel, ASTM A36
B65	Bearing	Bronze Oil Impregnated 30 & 36" (750 & 900mm)

**Note:** Fasteners are zinc plated steel unless stainless steel bolting is specified.

# Nut

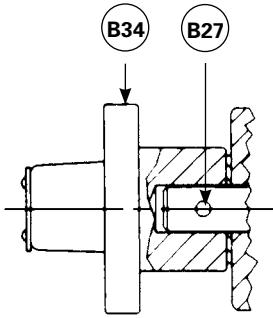

# Chainwheel 3-20" (80-500mm)

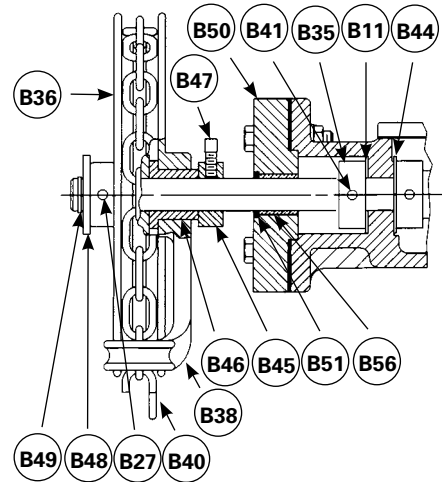
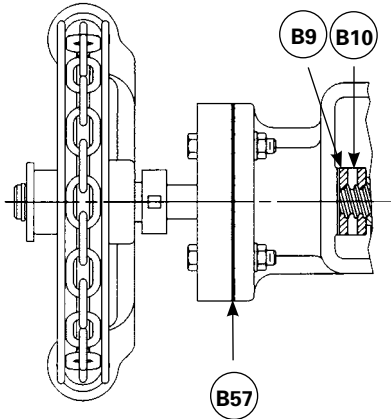

# Chainwheel 24-36" (600-900mm)

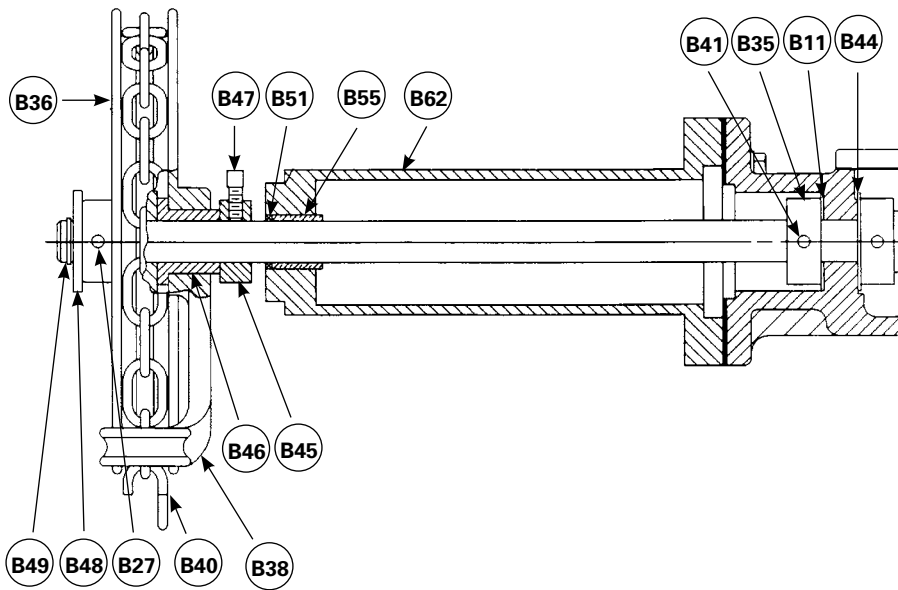

# LA-Series Manual Actuator

## LA-Series Actuator Materials of Construction

Item	Description	Material
B1	Housing	Cast Iron, ASTM A126 Class B
B2	Bearing	Bronze Oil Impregnated
B3	Yoke	Ductile Iron, ASTM A536 80-55-06
B4	Cover	Steel Plate, A36 HR
B5	Packing Retainer	Steel Plate, A36 HR
B6	Link	Steel
B7	Yoke Nut	Ductile Iron, ASTM A536 80-55-06
B8	Guide Nut (LA-4 & LA-6)	Powder Metal 8020 23B
B9	Retaining Ring	Carbon Steel, SAE 1060-1090
B10	Input Shaft	Steel, AISI 1141
B11	O-Ring	Acrylonitrile-Butadiene
B12	O-Ring	Acrylonitrile-Butadiene
B13	Collar	Steel, AISI 1215
B14	Pin	Steel
B15	Thrust Washer	Teflon/Glass Fabric, Stainless Steel Backing
B16	Thrust Washer	Teflon/Glass Fabric, Stainless Steel Backing
B17	Bearing	Bronze Oil Impregnated
B18	Expansion Plug	Steel Zinc Plated
B23	Retaining Washer	Stainless Steel, Type 18-8
B24	Outer Guide Bar	Steel, AISI 1018
B25	Inner Guide Bar	Steel, AISI 1018
B26	Square Nut	Steel, AISI 1018
B27	Stop Nut	Steel, AISI 1018
B28	Seal	Steel with Nitrile
B29	Pointer	Steel, ASTM A36
B32	Stud	Steel Zinc Plated
B33	Nut	Steel Zinc Plated
B34	Thread Seal	Steel with Nitrile
B35	Yoke Cover	Steel, ASTM A569
B40	Pin	Steel Zinc Plated
B43	Handwheel	Cast Iron, ASTM A126 Class B
B44	Position Plate	Vinyl
B45	Shim	Steel
B47	Expansion Plug	Steel Zinc Plated

Item	Description	Material
B48	Bushing	Bronze Oil Impregnated
B50	Chain Guide	Cast Iron, ASTM A126
B51	Closing Link	Steel
B52	Collar	Steel, ASTM A36
B53	Bearing	Bronze
B54	Screw	Steel Zinc Plated
B55	Washer	Steel Zinc Plated
B56	Retaining Ring	Carbon Steel
B57	Adaptor Plate	Steel, ASTM A36
B58	Seal	Garlock
B62	Bearing	Bronze
B63	Gasket	Non-Asbestos
B64	Adaptor	Cast Iron, ASTM A126 Class B
B65	Gasket	Non-Asbestos
B69	Housing (Spur Gear)	Cast Iron, ASTM A126
B70	Pin (Chainwheel)	Steel Zinc Plated
B71	Gasket	Fiber Non-Asbestos
B72	Screw	Steel Zinc Plated
B73	Screw	Steel Zinc Plated
B74	Seal	Steel Zinc Plated
B75	Pin	Steel Zinc Plated
B76	Pin	Steel Zinc Plated
B77	Retainer Ring	Steel Zinc Plated
B78	Cover	Steel Plate, ASTM A36
B81	Gear	Carbon Steel
B82	Gear	Carbon Steel
B83	Input Shaft (Spur Gear)	Steel, ASTM A29
B84	O-Ring	Nitrile
B85	Chainwheel	Cast Iron, ASTM A126 Class B
B88	Adaptor (Adj. Packing)	Steel, ASTM A36
B89	Bearing	Bronze
B90	Shaft Extension	Steel, AISI 1215
B91	Washer	Steel Zinc Plated
B92	Expansion Plug	Zinc Plated Steel
B93	Lockwasher	Zinc Plated Steel

Note: All fasteners are zinc plated steel unless stainless steel bolting is specified.

### Handwheel

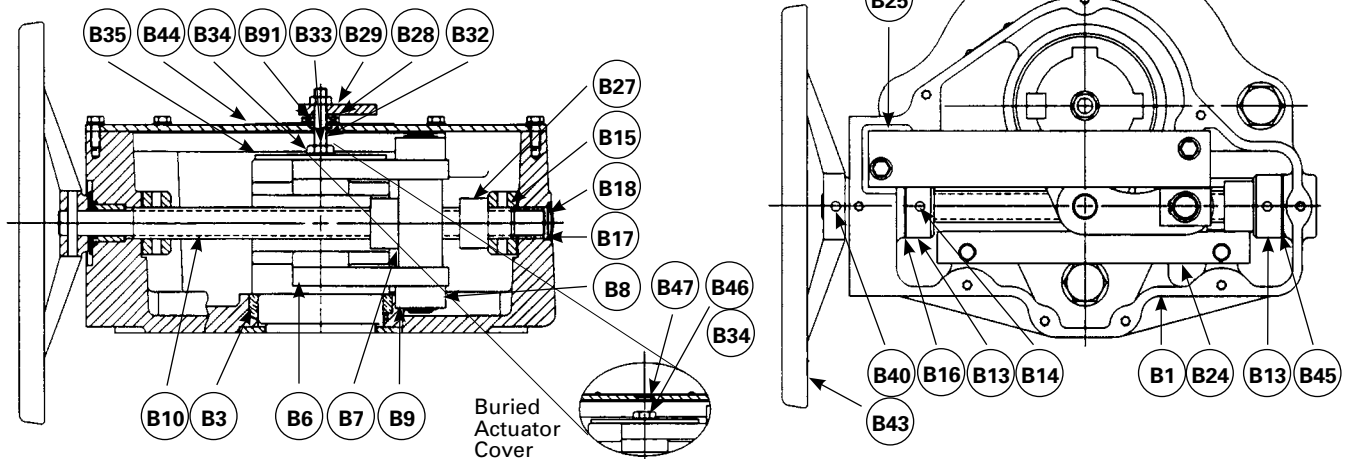

## Chainwheel

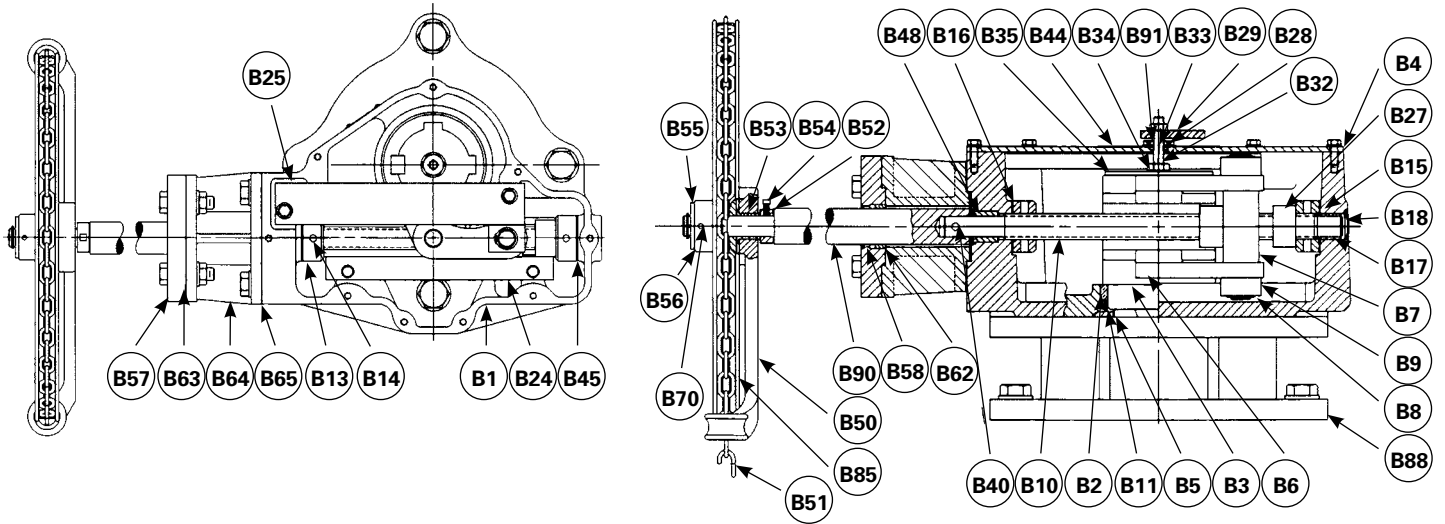

## Handwheel with Spur Gear

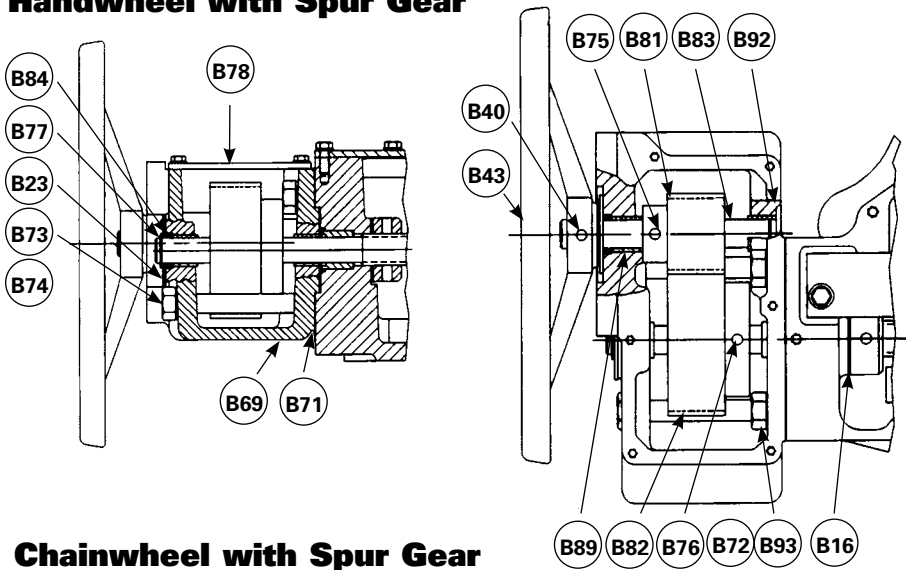

## Nut

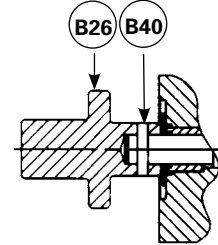

## Nut with Spur Gear

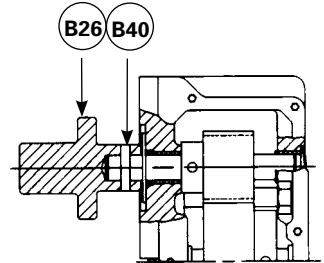

## Chainwheel with Spur Gear

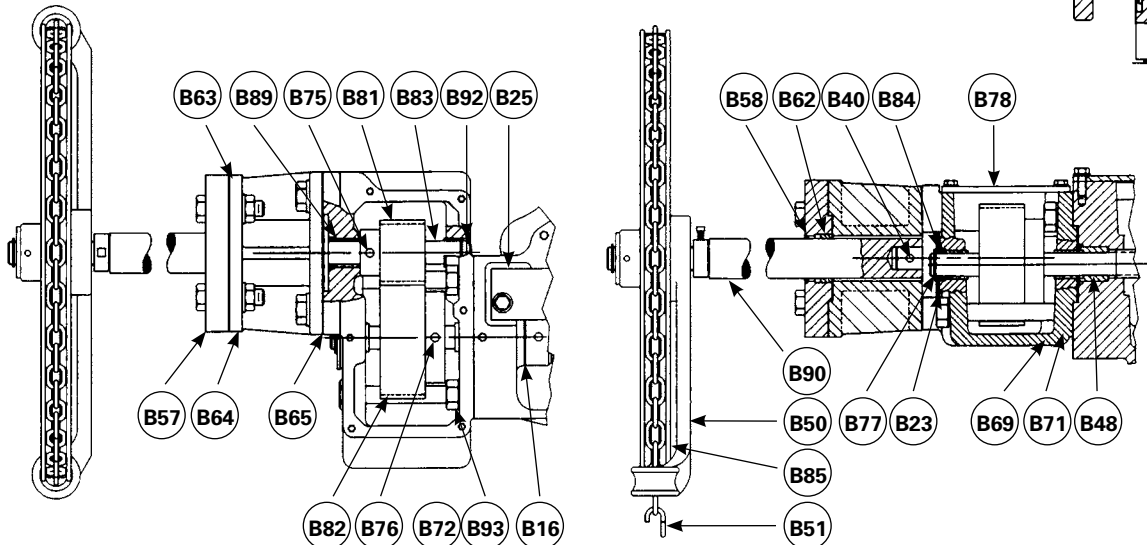

# T-Series Cylinder Actuator

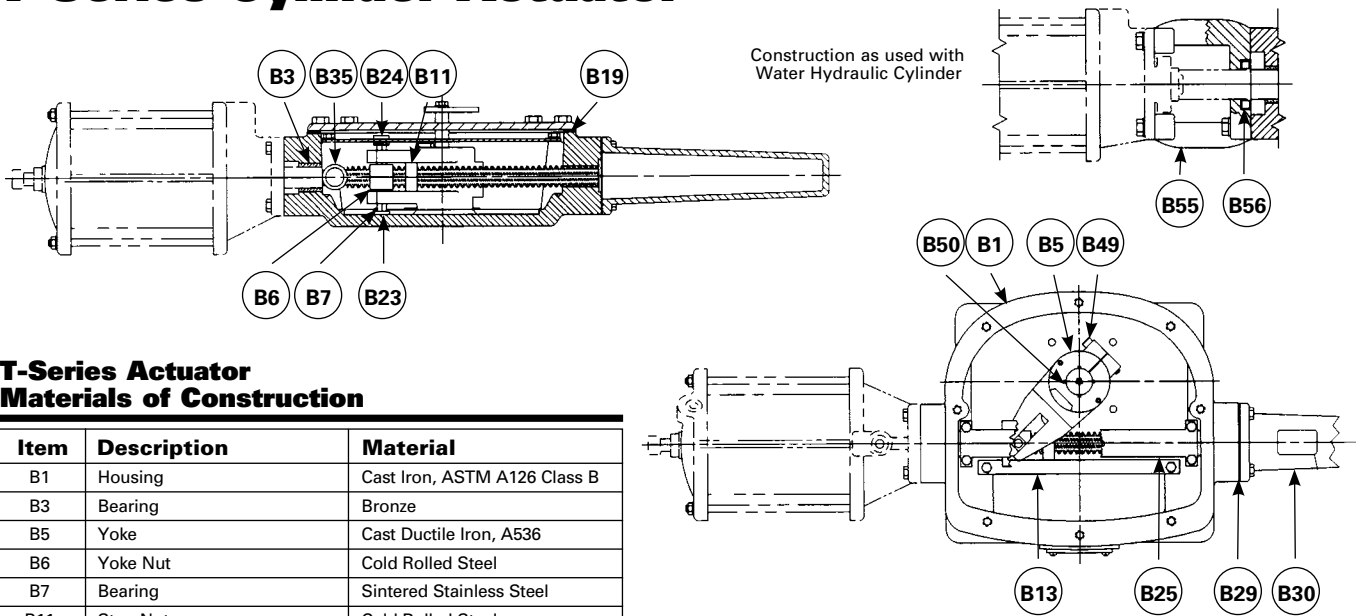

## T-Series Actuator Materials of Construction

Item	Description	Material
B1	Housing	Cast Iron, ASTM A126 Class B
B3	Bearing	Bronze
B5	Yoke	Cast Ductile Iron, A536
B6	Yoke Nut	Cold Rolled Steel
B7	Bearing	Sintered Stainless Steel
B11	Stop Nut	Cold Rolled Steel
B13	Guide Rail	Cold Rolled Steel
B19	Gasket	Neoprene
B23	Lower Yoke Guide (TW-7 only)	Steel, AISI 1215
B24	Upper Yoke Guide (TW-7 only)	Steel, ASTM A366
B25	Guide Rail (TW-7 only)	Steel, ASTM A36
B29	Gasket	Neoprene
B30	Cap	Fiberglass
B35	Stay Pin	Steel
B49	Screw	Alloy Steel
B50	Key	Steel, AISI 1018
B55	Adaptor (Hydraulic only)	Cast Iron, ASTM A126 Class B
B56	Wiper (Hydraulic only)	Carbon Steel

**Note:** All fasteners are zinc plated steel unless stainless steel bolting is specified.

## Pneumatic/Low Pressure Oil Hydraulic Standard and C-540

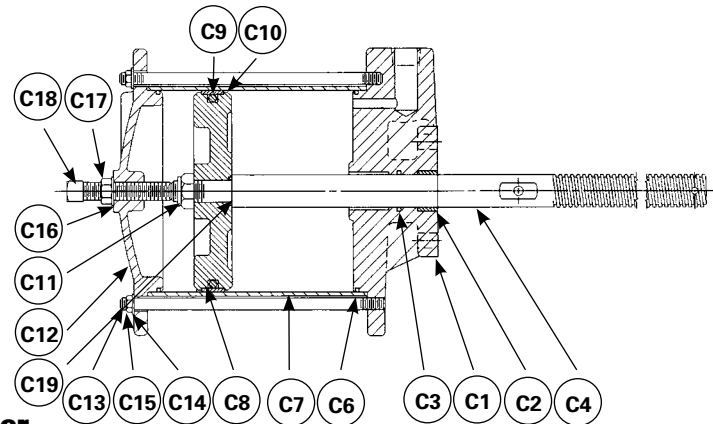

## Pneumatic/Low Pressure Oil Hydraulic Cylinder Materials of Construction

Item	Description	Standard Construction	C-540 Construction
C1	Cylinder Head	Cast Iron, ASTM A126 Class B	Ductile Iron, ASTM A536 65-45-12
C2	Bearing	Bronze Oil Impregnated	Bronze Oil Impregnated
C3	Rod Seal	Teflon with NBR	Teflon with NBR
C4	Piston Rod	Steel, AISI 1215 Chrome Plated	Steel, AISI 1215 Chrome Plated
C6	O-Ring	Acrylonitrile-Butadiene	Acrylonitrile-Butadiene
C7	Cylinder Tube	Fiberglass	Fiberglass
C8	Piston	Cast Iron, ASTM A126 Class B	Cast Iron, ASTM A126 Class B
C9	O-Ring	Acrylonitrile-Butadiene	Acrylonitrile-Butadiene
C10	Piston Seal	Virgin Teflon	Virgin Teflon
C11	Nut	Zinc Plated Steel	Zinc Plated Steel
C12	Cylinder Cap	Ductile Iron, ASTM A536 65-45-12	Ductile Iron, ASTM A536 65-45-12
C13	Tie Rod	Zinc Plated Steel	Steel, AISI C1018 Zinc Plated
C14	Washer	Zinc Plated Steel	Zinc Plated Steel
C15	Nut	Zinc Plated Steel	Zinc Plated Steel
C16	Seal Thread	Steel with Nitrile	Steel with Nitrile
C17	Jam Nut	Zinc Plated Steel	Zinc Plated Steel
C18	Set Screw	Zinc Plated Steel	Zinc Plated Steel
C19	O-Ring	Acrylonitrile-Butadiene	Acrylonitrile-Butadiene



# Valve Accessories

## Mechanical Joint Accessories

Accessories include bolts, nuts, packing and glands for both ends.

## Manual Actuators

### 10-Position Levers

A 10-position dial provides positive latching in open, closed and eight intermediate positions. A pointer indicates position of disc plus a notch in the handle allows use of a padlock to prevent unauthorized valve operation.

### Mounting

Lever actuators can be mounted at standard or 180°. Levers are available on 3–8" (80–200mm) valve sizes.



### Mounting Nut & Handwheel

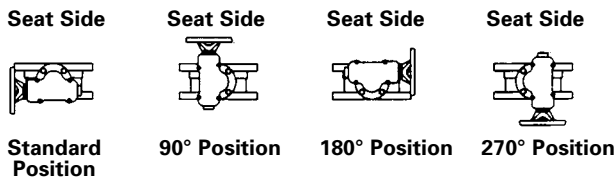

### Chainwheel

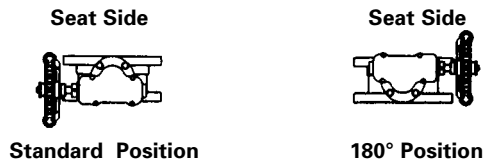

### M-Series Handwheel Mounting Positions

Valve Size	AWWA Class	Mounting Positions
3–12" (80–300mm)	150B	Std., 90, 180, 270
14–16" (350–400mm)	150B	Std., 180
18" (450mm)	150B	Std., 90, 180, 270
20" (500mm)	150B	Std., 180
24" (600mm)	75B 150B	Std., 90, 180, 270 Std., 180
30" (750mm)	25A 75A/75B	Std., 90, 180, 270 Std., 180
36" (900mm)	25A	Std., 180

### Rotating Manual Actuators

DeZURIK offers a variety of rotary manual actuators which are in complete compliance with AWWA C-504. Manual actuators are available with handwheel, chainwheel or 2" (50mm<sup>2</sup>) square nut options.

# Accessories — Manual Actuators

## 450 Ft-Lb (612 Nm) Input Stops

Available on M-Series actuators with handwheel or nut. LA-Series actuators have 450 Ft-Lb (612 Nm) input stops as standard.

## Chain — For Chainwheel Actuators

Chain for chainwheel actuators are available in zinc plated, galvanized or 304 stainless steel.

## Stainless Steel Bolting

Includes stainless steel fasteners on valve and actuator.

## Clockwise Rotation

Clockwise rotation to open (open right). Available with M-Series and LA Series Manual Actuators.

## Galvanized Chainwheel and Guide

Same as chainwheel actuator except chainwheel and guide are galvanized.

## Dial Indicating Floorstand

For valves with handwheel actuators. Actuator is mounted on the valve and the input shaft is extended to the floorstand. Included with the floorstand are the handwheel mounted on the floorstand, dial indicator and couplings. Extension rod must be ordered separately. Floorstand may be directly above valve or offset from valve location. A buried actuator must be specified when ordering an FSDI.

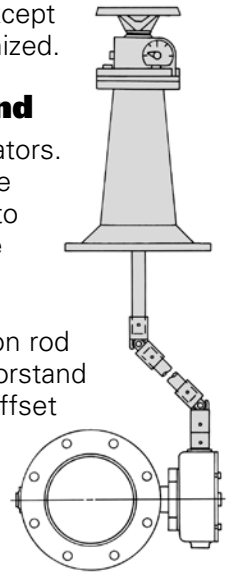

## Extension Rod

Extension rod is required for use with FSDI floorstand.

## Actuator Mounted on Floorstand

Included with floorstand are the couplings, extension pipe and mounting of actuator on floorstand.

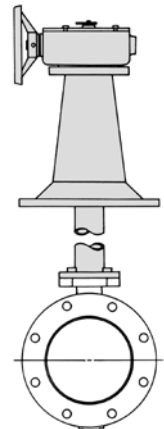

## Neck Extensions

Included is an extended valve neck and shaft. Valves for use with neck extensions must be furnished with non-adjustable packing and a non-buried actuator. Extensions are not recommended for use with positioners.

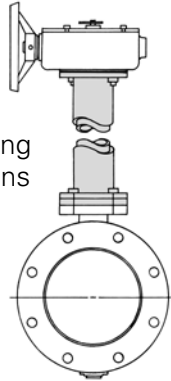

## Extended Nut for Manual Actuators

For actuators used with floorboxes and valve boxes. Includes couplings, extension rod and extended 2" (50mm) square nut.

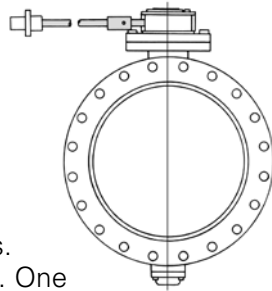

## Valve Box and Valve Box Extensions

For use with buried actuators. Includes valve box and cover. One to five extension pieces may be ordered to extend depth of valve box. Valve boxes may be used with valves having standard or extended nut actuators. Top of nut must be 6" (150mm) below grade. Valve boxes are tee wrench actuated. Tee wrenches must be ordered separately.

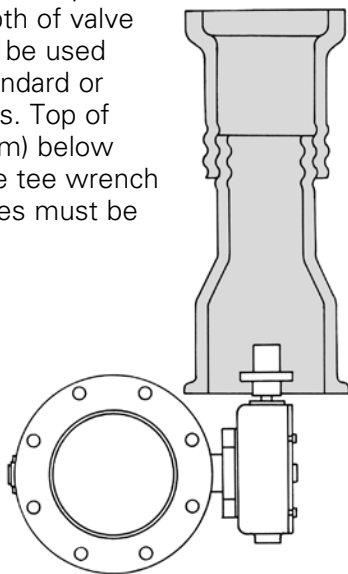

## Floorbox

For use with nut style actuators. It includes floorbox and cover. May be used with valves having standard or extended nut actuators. Top of nut must be 2" (50mm) from top of floorbox. Floorboxes are tee wrench actuated. Tee wrenches must be ordered separately. Box depth is available in 1" (25mm) increments from 6" (150mm) through 18" (450mm). Standard is 6" (150mm).

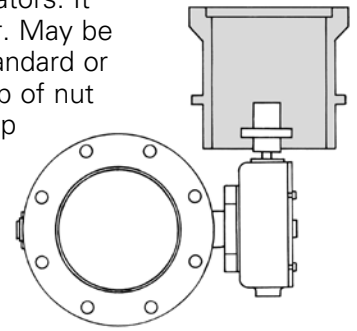

## Tee Wrench

For use in actuating 2" (50mm) nut actuators. Available in 4, 5, 6, 7 or 8 foot lengths. Other lengths available on special order.

## Cylinder Actuators

DeZURIK cylinder actuators are available as double-acting pneumatic or water hydraulic cylinders for either on-off or positioning services. Cylinder actuators per AWWA C-540 should be specified.

## Mounting

Cylinder actuators can be mounted at 90° increments from standard.

## Manual and Throttling Manual Override

Contact Application Engineer for assistance.

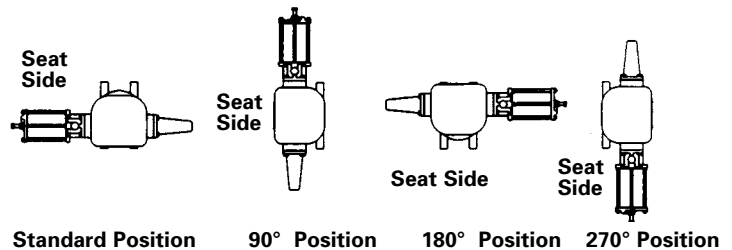

## G- Series

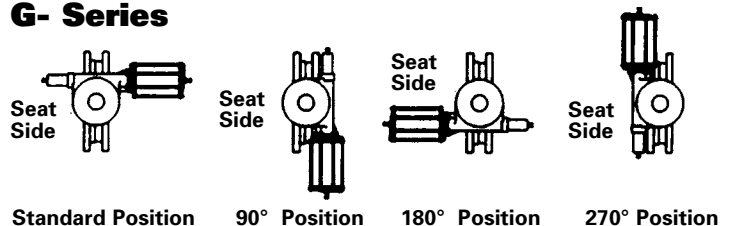

## Electric Motors

When ordering electric motor actuators, please provide information listed on "Data Input Checklist" at end of bulletin.

# Accessories — Cylinder Actuators

## Positioners

DeZURIK offers both pneumatic and electronic signal valve positioners for use with cylinder actuators.

## Gauges

Pneumatic positioners are available with three gauges mounted and piped; electronic positioners are available with two gauges mounted and piped.

## 4-Way Solenoid Valves

For cylinder actuators, 4-way direct acting, two position solenoid valves feature metal enclosures, .25" (6mm) NPT connections, Cv of .70 and a maximum pressure differential of 125 psi (8.5 Bar). Solenoid coil voltage is both 110/50/1 and 120/60/1 AC power. Contact Sartell Valves, Inc. for DC voltage. Solenoids are available with or without manual overrides. On large valves, furnish valve/actuator size, service conditions, and required operating speed for recommendations. Solenoid action should be specified.

## Air Filter Regulator

For use on all pneumatic actuators. Includes a pressure reducing valve with filter and gauge. Maximum supply is 100 psi (7 Bar).

## Speed Control Valves

Speed control valves are available for controlling opening and closing speed on cylinder actuators.

## Position Indicating Switches

Available in NEMA 4, 4x, 7 or 9 ratings. Switches are available as two SPDT or four SPDT.

## Floorstand

For valves with cylinder actuators mounted on floorstand. Included with the floorstand are couplings, the extension pipe and mounting of the actuator on the floorstand.

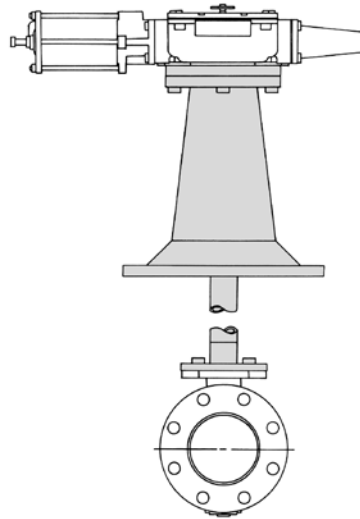

## Neck Extension

For 3–20" (80–500mm) valves using T-Series Cylinder actuators. Included is the extended valve neck and shaft with actuator mounted.

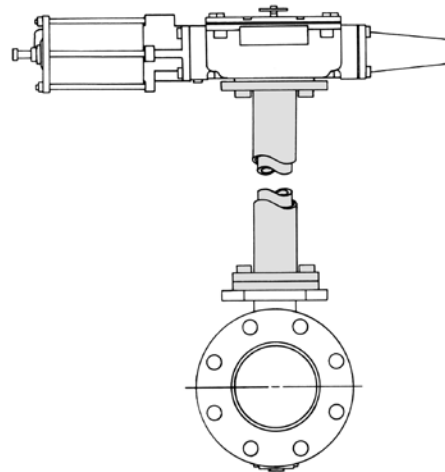

# Dimensions

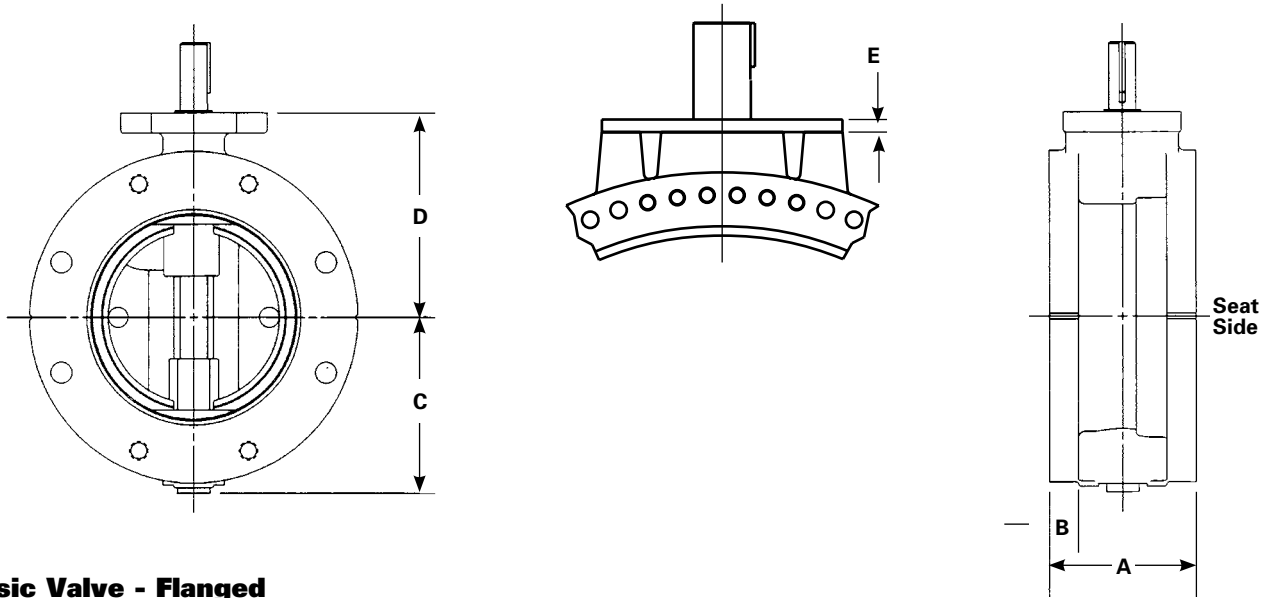

## Basic Valve - Flanged

Valve Size	A		B		C		D		E
	25A, 75B & 150B*	250B	25A, 75B & 150B*	250B	25A, 75B & 150B*	250B	25A, 75B & 150B*	250B	250B Only
3" 80mm	5.00 127	5.00 127	.81 21	1.19 30	4.00 102	4.12** 105	4.81 122	4.81 122	-
4" 100mm	5.00 127	5.00 127	1.00 25	1.31 33	4.75 121	5.00** 127	5.56 141	5.56 141	-
6" 150mm	5.00 127	5.00 127	1.06 27	1.50 38	6.03 153	6.25** 159	7.00 178	7.00 178	-
8" 200mm	6.00 152	6.00 152	1.19 30	1.69 43	7.16 182	7.50** 191	8.31 211	8.31 211	-
10" 250mm	8.00 203	8.00 203	1.25 32	1.97 50	8.38 213	8.75** 222	9.50 241	9.50 241	-
12" 300mm	8.00 203	8.00 203	1.31 33	2.09 53	9.66 245	10.25** 260	11.00 279	11.00 279	-
14" 350mm	8.00 203	8.00 203	1.47 37	2.25 57	10.91 277	11.50** 292	11.50 292	11.50 292	-
16" 400mm	8.00 203	8.00 203	1.53 39	2.38 60	12.06 306	12.75** 324	12.75 324	12.75 324	-
18" 450mm	8.00 203	8.00 203	1.66 42	2.50 64	14.03 356	14.50 368	13.50 343	14.00 356	-
20" 500mm	8.00 203	8.00 203	1.78 45	2.63 67	15.02 382	17.50 445	15.25 387	15.25 387	-
24" 600mm	8.00 203	12.00 305	1.97 50	2.91 74	19.00 483	20.19 513	18.41 468	19.50 495	-
30" 750mm	12.00 305	12.00 305	2.25 57	3.13 80	23.00 584	23.75 603	22.62 575	21.75 552	1.25 32
36" 900mm	12.00 305	15.00 381	2.50 64	3.50 89	27.38 696	27.38 695	25.62 651	25.62 651	1.25 32
42" 1100mm	12.00 305	15.00 381	2.75 70	3.81 97	30.91 785	30.91 785	30.42 773	30.42 773	1.25 32
48" 1200mm	15.00 381	15.00 381	2.88 73	4.13 105	35.38 899	35.38 899	33.00 838	33.00 838	1.25 32

Inches  
Millimeter

Contact DeZURIK for dimensions on valve sizes 54" (1400mm) and larger.

\*Available in AWWA Class 250B when ordered with 17-4 Shaft and 250 psi bearings.

\*\*Flange length exceeds thrust bearing cover in these valve sizes.

**Note:** All dimensions are subject to change without notice. Request certified drawings for use in preparing piping layouts.

# Dimensions

## Basic Valve — Mechanical Joint

Valve Size	A	B	C	D	E
4" 100mm	8.56 217	4.75 121	4.75 121	5.56 141	2.50 64
6" 150mm	8.88 226	4.75 121	6.03 153	7.00 178	2.50 64
8" 200mm	9.50 241	5.00 127	7.16 182	8.31 211	2.50 64
10" 250mm	9.88 251	5.25 133	8.38 213	9.50 241	2.50 64
12" 300mm	10.00 254	5.38 137	9.66 245	11.00 279	2.50 64
14" 350mm	12.38 315	6.62 168	10.91 277	11.50 292	3.50 89
16" 400mm	12.75 324	6.75 171	12.06 306	12.75 324	3.50 89
18" 450mm	13.42 341	7.00 178	14.03 356	13.50 343	3.50 89
20" 500mm	13.38 340	7.12 181	15.02 382	15.25 387	3.50 89
24" 600mm	13.75 349	7.50 191	19.00 483	18.41 468	3.50 89
30" 750mm	17.75 451	9.62 244	23.00 584	22.62 575	4.00 102
36" 900mm	18.00 458	10.00 254	27.38 696	25.62 651	4.00 102
42" 1100mm	18.75 476	10.25 260	30.91 785	30.41 772	4.00 102
48" 1200mm	19.62 498	10.62 270	35.38 898	33.00 838	4.00 102

Inches  
Millimeter

**Note:** All dimensions are subject to change without notice.  
Request certified drawings for use in preparing piping layouts.

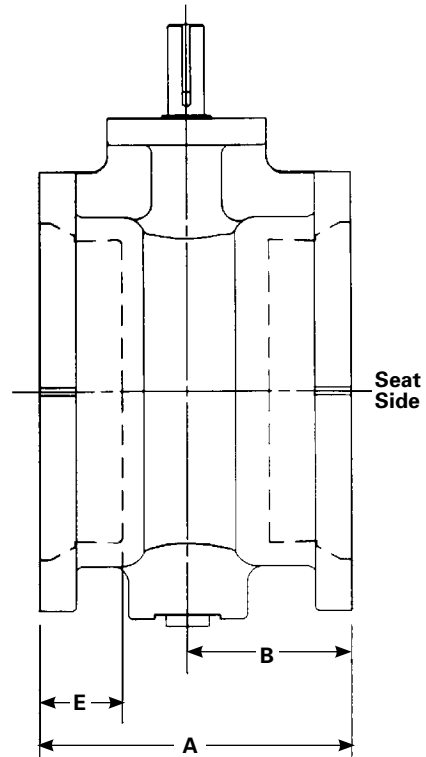
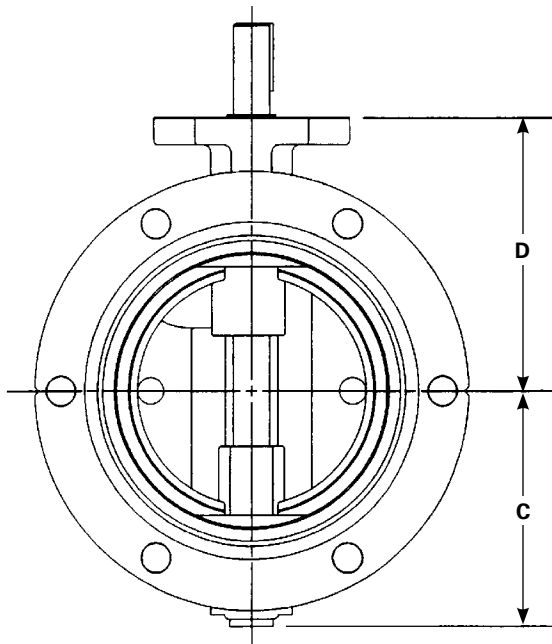

### Lever Actuator

Valve Size	M	N	P	R
3-4" 80-100mm	2.56 65	3.56 90	3.00 76	14.00 356
6-8" 150-200mm	2.88 73	3.56 90	3.00 76	14.00 356

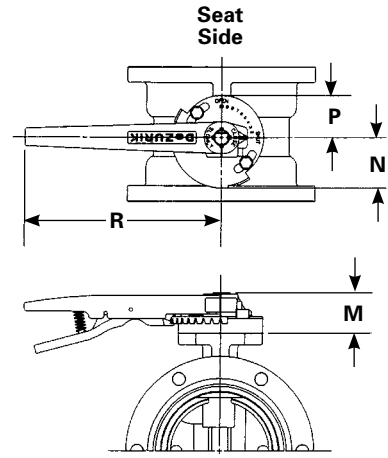

### Handwheel Actuator M-Series 3-24" (80-600mm)

Valve Size (Handwheel Size)	F	G	H	I	J	K	L
3-10" 8-250mm	7.44 189	4.75 121	1.62 41	3.62 92	8.00 203	2.25 57	5.00 127
12-14" 300-350mm	11.69 297	4.75 121	1.62 41	3.62 92	16.00 406	2.25 57	5.00 127
16-18" 400-450mm	9.81 249	7.25 184	3.50 89	7.19 183	8.00 203	2.19 56	5.19 132
20" 500mm	14.06 357	7.25 184	3.50 89	7.19 183	16.00 406	2.19 56	5.19 132
24" 600mm (HD12)	10.06 256	7.25 184	3.50 89	7.19 183	12.00 305	2.19 56	5.19 132
24" 600mm (HD16)	13.06 332	7.25 184	3.50 89	7.19 183	16.00 406	2.19 56	5.19 132
24" 600mm (HD24)	15.69 399	7.25 184	3.50 89	7.19 183	24.00 610	2.19 56	5.19 132

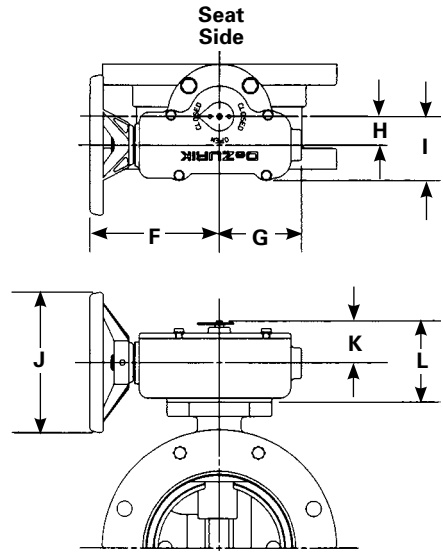

### Handwheel Actuator M-Series 30" (750mm)

Valve Size (Handwheel Size)	F	G	H	I	J	K	L	M
30" 750mm (HD24)	15.69 399	8.25 210	3.50 89	7.19 183	24.00 610	3.19 81	6.19 157	8.25 210
30" 750mm (HD36)	21.00 533	8.25 210	3.50 89	7.19 183	36.00 914	3.19 81	6.19 157	8.25 210

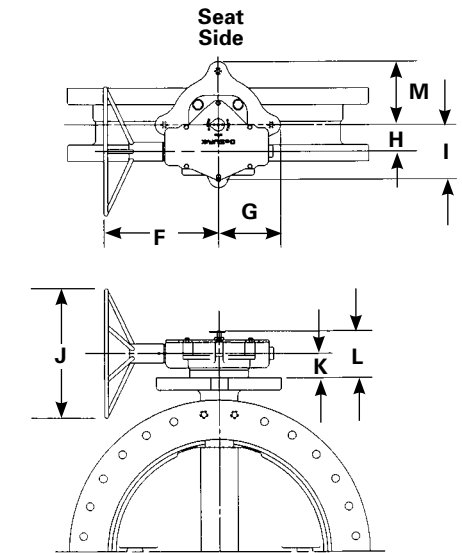

Inches  
Millimeter

# Dimensions (continued)

## Chainwheel Actuator M-Series 3-20" (80-500mm)

Valve Size	F	G	H	I	J	K	L
3-10" 8-250mm	10.38 264	4.75 121	1.62 41	3.62 92	9.19 233	2.25 57	5.00 127
12" 300mm	12.78 325	4.75 121	1.62 41	3.62 92	9.19 233	2.25 57	5.00 127
14-16" 350-400mm	14.78 375	4.75 121	1.62 41	3.62 92	20.06 510	2.25 57	5.00 127
18" 450mm	15.19 386	7.25 184	3.50 89	7.19 183	9.19 233	2.19 56	5.19 132
20" 500mm	16.00 406	7.25 184	3.50 89	7.19 183	20.06 510	2.19 56	5.19 132

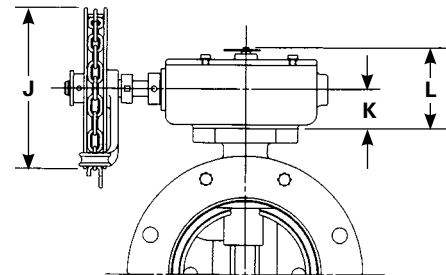
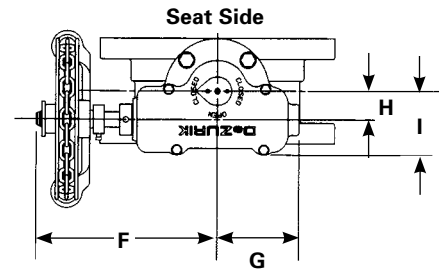

## Chainwheel Actuator M-Series 24-30" (600-750mm)

Valve Size (Chainwheel Size)	F	G	H	I	J	K	L
24" 600mm (MS-7-CW20)	25.62 651	7.25 184	3.50 89	7.19 183	20.06 510	2.19 56	5.19 132
30" 750mm (MS-7-CW20)	25.62 651	8.25 210	3.50 89	7.19 183	20.06 510	3.19 81	6.19 157

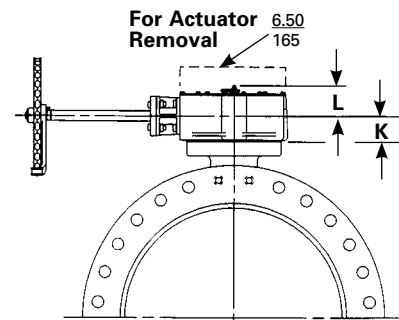
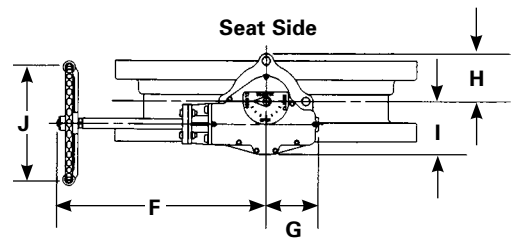

## Nut (M-Series)

Valve Size	F	G	H	I	J	K	L
3-14" 80-350mm	7.38 188	4.75 121	1.62 41	3.62 92	2.00 51	2.25 57	5.00 127
16-24" 400-600mm	9.75 248	7.25 184	3.50 89	7.19 183	2.00 51	2.19 56	5.19 132
30" 750mm	10.25 260	7.56 192	4.00 102	8.12 206	2.00 51	3.06 78	5.94 151

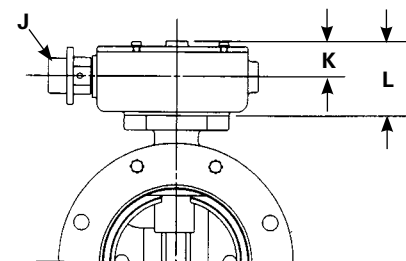
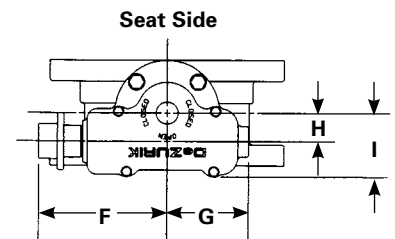

Inches  
Millimeter

Note: All dimensions are subject to change without notice.  
Request certified drawings for use in preparing piping layouts.

### Cylinder Actuator (T-Series)

Valve Size (Cylinder Size)	F		G	H	I	J	K	L
	Pneumatic	Hydraulic						
3-12" 80-300mm (C4)	18.12 460	21.12 536	16.31 414	3.25 83	5.94 151	5.38 137	1.81 46	4.69 119
12" 300mm (C6)	18.88 480	21.88 556	16.31 414	3.25 83	5.94 151	7.88 200	1.81 46	4.69 119
14-16" 350-400mm (C6)	23.44 595	26.44 672	17.88 454	4.44 113	8.12 206	7.88 200	3.12 79	5.84 148
18-20" 450-500mm (C6)	23.44 595	26.44 672	17.88 454	4.44 113	8.12 206	7.88 200	3.12 79	6.03 153
18-20" 450-500mm (C8)	24.06 611	27.06 687	17.88 454	4.44 113	8.12 206	10.25 260	3.12 79	6.03 153

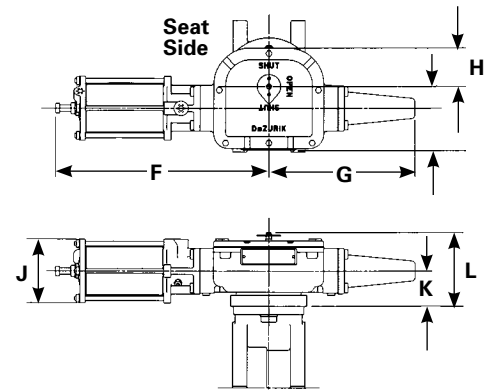

### Cylinder Actuator (G-Series)

Valve Size (Cylinder Size)	F		G	H	I	J	K
	Pneumatic	Hydraulic					
24" 600mm (GS-12-PC8)	31.50 800	32.75 832	17.50 445	6.88 175	4.25 108	8.50 216	3.25 83
24" 600mm (GS-12-PC10)	31.62 803	33.88 861	17.50 445	6.88 175	5.25 133	10.50 267	3.25 83
24" 600mm (GS-16-PC10)	43.88 1115	41.78 1061	24.25 616	9.00 229	5.88 149	11.75 298	3.50 89
30" 750mm (GS-12-PC8)	31.50 800	32.75 832	17.50 445	6.88 175	4.25 108	8.50 216	3.50 89
30-36" 750-900mm (GS-12-PC10)	31.62 803	33.88 861	17.50 445	6.88 175	5.25 133	10.50 267	3.50 89
30-42" 750-1100mm (GS-16-PC10)	43.25 1099	41.78 1061	24.25 616	9.00 229	5.88 149	11.75 298	3.75 95
36-42" 900-1100mm (GS-16-PC12)	44.62 1133	43.50 1105	24.25 616	9.00 229	7.00 178	14.00 356	3.75 95

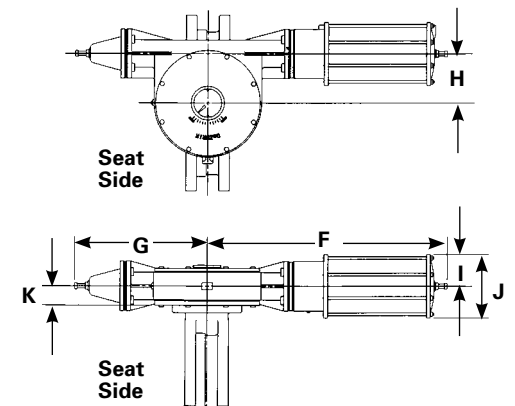

### Nut (LA-Series)

Valve Size (Actuator Size)	F	F with Spur Gear	G	H	I	J	K	
30-42" 750-1100mm (LA-4)	14.19 360	20.81 529	9.38 238	8.25 210	9.44 240	2.00 51	4.41 112	6.25 159
36-54" 900-1400mm (LA-6)	16.19 411	22.81 579	12.12 308	8.25 210	11.12 282	2.00 51	4.41 112	6.25 159
42-54" 1100-1400mm (LA-10)	20.19 513	26.81 681	16.81 427	8.25 210	16.12 409	2.00 51	4.81 122	5.84 148

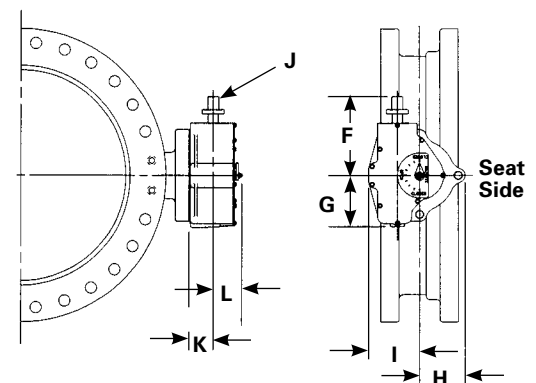

Inches  
Millimeter

# Dimensions (continued)

## Handwheel LA-Series 30-48" (750-1200mm)

Actuator Size	F	F with Spur Gear	G	H	I	J	K	L
LA-4-HD12	11.62 295	18.25 464	9.38 238	8.25 210	9.44 240	12.00 305	4.41 112	6.25 159
LA-4-HD16	12.25 311	18.88 480	9.38 238	8.25 210	9.44 240	16.00 406	4.41 112	6.25 159
LA-4-HD24	20.25 514	26.88 683	9.38 238	8.25 210	9.44 240	24.00 610	4.41 112	6.25 159
LA-4-HD30	22.88 581	29.50 749	9.38 238	8.25 210	9.44 240	30.00 762	4.41 112	6.25 159
LA-4-HD36	25.50 648	32.12 816	9.38 238	8.25 210	9.44 240	36.00 914	4.41 112	6.25 159

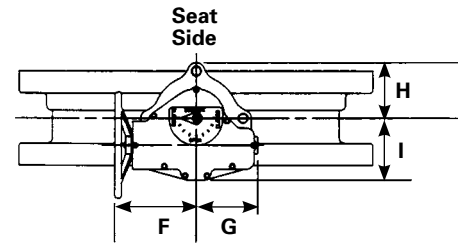

## Handwheel LA-Series 36-54" (900-1400mm)

Actuator Size	F	F with Spur Gear	G	H	I	J	K	L
LA-6-HD12	13.62 346	20.25 514	12.12 308	8.25 210	11.12 282	12.00 305	4.41 112	6.25 159
LA-6-HD16	14.25 362	20.88 530	12.12 308	8.25 210	11.12 282	16.00 406	4.41 112	6.25 159
LA-6-HD24	22.25 565	28.88 734	12.12 308	8.25 210	11.12 282	24.00 610	4.41 112	6.25 159
LA-6-HD30	24.88 632	31.50 800	12.12 308	8.25 210	11.12 282	30.00 762	4.41 112	6.25 159
LA-6-HD36	27.50 699	34.12 867	12.12 308	8.25 210	11.12 282	36.00 914	4.41 112	6.25 159

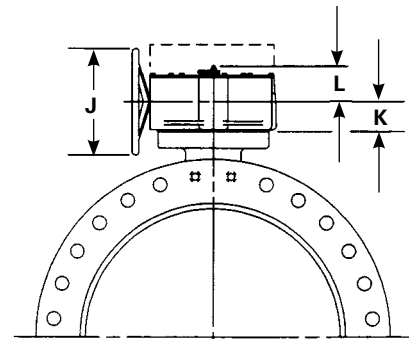

## Handwheel LA-Series 42-54" (1100-1400mm)

Actuator Size	F	F with Spur Gear	G	H	I	J	K	L
LA-10-HD12	17.62 448	24.25 616	16.81 427	8.25 210	16.12 409	12.00 305	4.81 122	5.84 148
LA-10-HD16	18.25 464	24.88 632	16.81 427	8.25 210	16.12 409	16.00 406	4.81 122	5.84 148
LA-10-HD24	26.25 667	32.88 835	16.81 427	8.25 210	16.12 409	24.00 610	4.81 122	5.84 148
LA-10-HD30	28.88 734	35.50 902	16.81 427	8.25 210	16.12 409	30.00 762	4.81 122	5.84 148
LA-10-HD36	31.50 800	38.12 968	16.81 427	8.25 210	16.12 409	36.00 914	4.81 122	5.84 148

Inches  
Millimeter

**Note:** All dimensions are subject to change without notice.  
Request certified drawings for use in preparing piping layouts.

**Chainwheel LA-Series 30-48" (750-1200mm)**

Actuator Size	F	F with Spur Gear	G	H	I	J	K	L
LA-4-CW12	35.00 889	41.62 1057	9.38 238	8.25 210	9.44 240	12.75 324	4.41 112	6.25 159
LA-4-CW20	35.00 889	41.62 1057	9.38 238	8.25 210	9.44 240	20.06 510	4.41 112	6.25 159
LA-4-CW30	35.00 889	41.62 1057	9.38 238	8.25 210	9.44 240	29.75 756	4.41 112	6.25 159

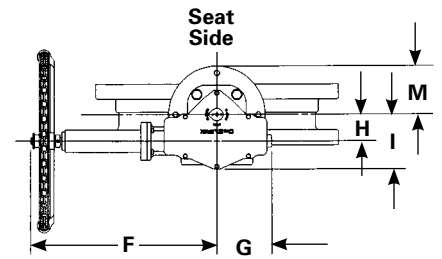

**Chainwheel LA-Series 36-54" (900-1400mm)**

Actuator Size	F	F with Spur Gear	G	H	I	J	K	L
LA-6-CW12	37.00 940	43.62 1108	12.12 308	8.25 210	11.12 282	12.75 324	4.41 112	6.25 159
LA-6-CW20	37.00 940	43.62 1108	12.12 308	8.25 210	11.12 282	20.06 510	4.41 112	6.25 159
LA-6-CW30	37.00 940	43.62 1108	12.12 308	8.25 210	11.12 282	29.75 756	4.41 112	6.25 159

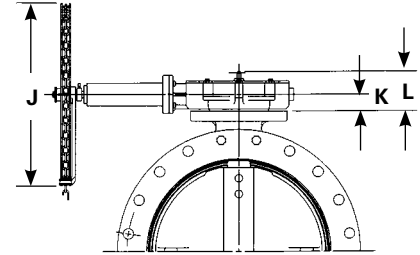

**Chainwheel LA-Series 42-54" (1100-1400mm)**

Actuator Size	F	F with Spur Gear	G	H	I	J	K	L
LA-10-CW12	41.00 1041	47.62 1210	16.81 427	8.25 210	16.12 409	12.75 324	4.81 122	5.84 148
LA-10-CW20	41.00 1041	47.62 1210	16.81 427	8.25 210	16.12 409	20.06 510	4.81 122	5.84 148
LA-10-CW30	41.00 1041	47.62 1210	16.81 427	8.25 210	16.12 409	29.75 756	4.81 122	5.84 148

Inches  
Millimeter

**Note:** All dimensions are subject to change without notice.  
Request certified drawings for use in preparing piping layouts.

# DeZURIK Butterfly Valve Applications Data Input Checklist

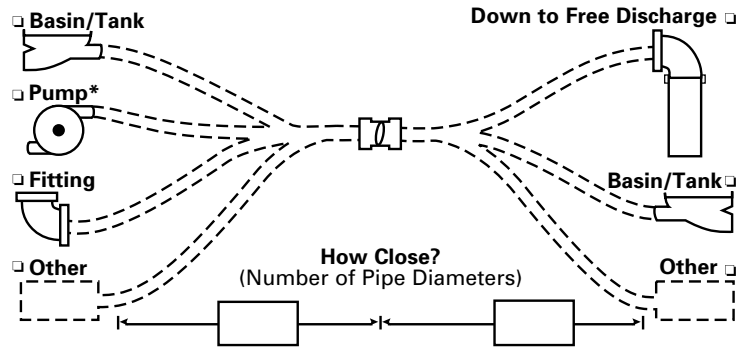

**Part A:** Check boxes and complete lines to show upstream/downstream configuration, enter distances in pipe diameters.

## Part B: Check off or enter operating conditions.

- Valve Function?  Open/Shut  Throttling  Modulating Control
- Where Installed?  Buried  Submerged  Above Ground, In Plant
- Line Fluid?  Fresh Water  Sewage  Air  Other? \_\_\_\_\_
- Maximum Fluid Temperature? \_\_\_\_\_ °C \_\_\_\_\_ °F
- Line Size? \_\_\_\_\_ inches \_\_\_\_\_ (mm) (nominal)
- Normal Working Pressure? \_\_\_\_\_ psi \_\_\_\_\_ kPa  
Maximum (Shutoff) Pressure Differential? \_\_\_\_\_ psi \_\_\_\_\_ kPa
- Normal Wide Open Valve Flow? \_\_\_\_\_ flow rate or \_\_\_\_\_ flow units
- Emergency Maximum (Line Break, Etc.) Flow? \_\_\_\_\_ flow rate \_\_\_\_\_ flow units
- (If Throttling or Modulating Control) Flow Range Desired?  
Maximum Flow? \_\_\_\_\_ flow rate \_\_\_\_\_ flow units  
Minimum Flow? \_\_\_\_\_ flow rate \_\_\_\_\_ flow units
- Pipe Connection? \_\_\_\_\_ Flanged \_\_\_\_\_ Mechanical Joint \_\_\_\_\_ Other

## Part C: Check off or enter operator requirements.

- Operator Type? Manual:  Lever  Lead Screw  Gear  Other?  
Power:  Cylinder  Electric  Other?
- Direction of Rotation To Open:  Clockwise—(OR)  Counter clockwise—(OL)
- Cylinder Specifications:
  - Supply Type and Pressure?  Water \_\_\_\_\_ psi \_\_\_\_\_ kPa  Oil \_\_\_\_\_ psi \_\_\_\_\_ kPa  
 Air \_\_\_\_\_ psi \_\_\_\_\_ kPa  Other \_\_\_\_\_ psi \_\_\_\_\_ kPa
  - Fail Safe?  Yes  No; If yes which way if valve fails?  Open  Close
  - Operating Times? \_\_\_\_\_ sec Open to Close; \_\_\_\_\_ sec Close to Open
  - Accessories?
 

<input type="checkbox"/> Speed Control	<input type="checkbox"/> Limit Switches (ES) (Qty: _____ O, _____ C, _____ I)
<input type="checkbox"/> Solenoid W/Manual Override	<input type="checkbox"/> Positioner
<input type="checkbox"/> Manual Override (On loss of supply press.)	<input type="checkbox"/> Solenoid W/O Manual Override
<input type="checkbox"/> Other? _____	
- Electric Specifications:
  - Supply? \_\_\_\_\_ Volts \_\_\_\_\_ Phase \_\_\_\_\_ Hz
  - Duty Cycle?  Intermittent  Continuous
  - Starter/Control Needs? \_\_\_\_\_
  - Operating Times? \_\_\_\_\_ sec (Note: 60 sec per AWWA unless specified)
  - Accessories?
 

<input type="checkbox"/> AUX Switches	<input type="checkbox"/> Potentiometer	<input type="checkbox"/> Slidewire Receiver	<input type="checkbox"/> Reversing Starter
<input type="checkbox"/> Heaters	<input type="checkbox"/> Control Station	<input type="checkbox"/> Control Transformer	<input type="checkbox"/> Other? _____



## **Sales and Service**

For information about our worldwide locations, approvals, certifications and local representative:

Web Site: [www.dezurik.com](http://www.dezurik.com) E-Mail: [info@dezurik.com](mailto:info@dezurik.com)



250 Riverside Ave. N. Sartell, Minnesota 56377 • Phone: 320-259-2000 • Fax: 320-259-2227

*DeZURIK reserves the right to incorporate our latest design and material changes without notice or obligation. Design features, materials of construction and dimensional data, as described in this bulletin, are provided for your information only and should not be relied upon unless confirmed in writing by DeZURIK. Certified drawings are available upon request.*