

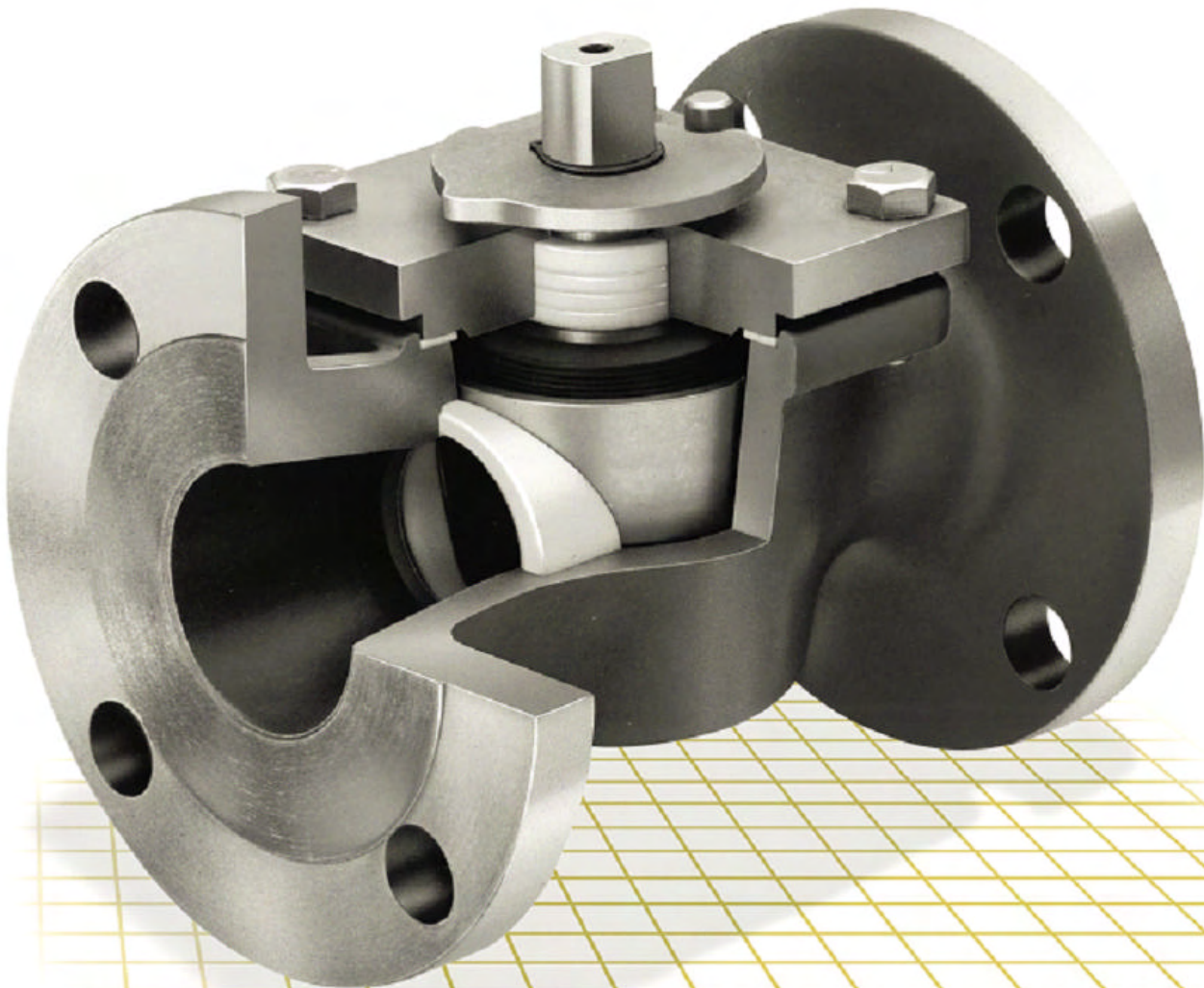

# PERMASEAL PLUG VALVES



**Design and Construction**

Permaseal® Plug Valves are designed for on-off and diverting applications in the chemical, power, mining and paper industries. They are designed to handle clean, viscous and corrosive liquids; clean and corrosive gases; and low pressure steam.

The unique design of SMG's Permaseal® Plug Valve includes a non-lubricated, tapered plug and two individual seats that provide a double seal and bi-directional shutoff. Ranging in sizes from 0.5–6" (15–150mm), they offer corrosion resistance and temperature ratings to 1000°F (540°C). Pressure ratings include ANSI Class 150 for applications to 285 psi (1960 kPa) and ANSI Class 300 for services to 740 psi (5100 kPa).

Permaseal® Plug Valves are available in 316 stainless steel, carbon steel, Alloy 20, Monel, Hastelloy C and other alloys including Inconel. Several body designs are available for various process applications including two-way, three-way, jacketed, flush-through and double block and bleed valves. The Permaseal® Plug Valve is also available with modified construction for chlorine service and bellows stem seals for controlling fugitive emissions.

**Pressure Relief Design Offers Automatic Flushing**

The self-adjusting plug in the Permaseal® valve features a pressure relief hole in the plug that allows flushing of the lower cavity. When the valve is being opened or closed, flow is created through the pressure relief hole in the bottom of the plug and out the downstream port. Accumulation of contaminants is eliminated by this flushing action during normal valve actuation. Elimination of contamination problems is especially important on radiation and molten sulfur services.

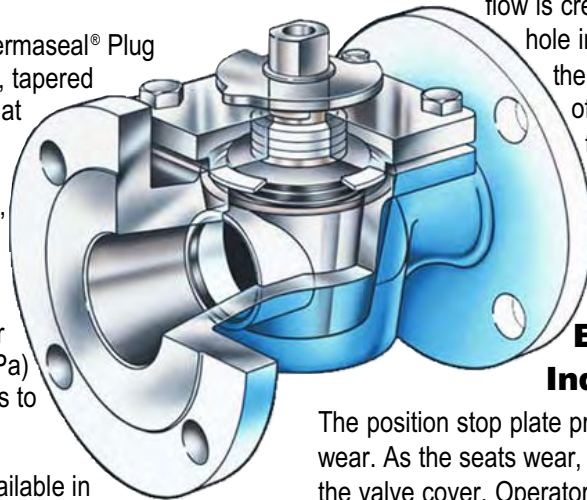

**External Seat Wear Indicator**

The position stop plate provides external indication of seat wear. As the seats wear, the stop plate moves closer to the valve cover. Operators can easily determine when contact is made, indicating the seats should be replaced.

**Seat Wiping Action Prevents Material Build-Up and Wear**

Wiping action of the plug on the raised seats prevents the build-up of material that can cause excessive wear and shorten life. This is especially beneficial in crude oil applications that contain sand or other entrained materials.

**Dynamic Stem Seal Assures Long Life and Reduced Maintenance**

Thrust from the Belleville washers provides a live-loaded, self-adjusting stem seal. Uniform pressure on the multiple ring packing continuously adjusts for wear to assure a long-life stem seal and reduced maintenance.

**Self-Adjusting Plug Compensates for Wear**

Compressed Belleville washers provide positive contact between the tapered plug and the seats. The Belleville washers are located between the plug and the bonnet, distributing a constant thrust on the plug to compensate for seat wear, thermal expansion and contraction. The Permaseal® design does not rely on line pressure for tight sealing.

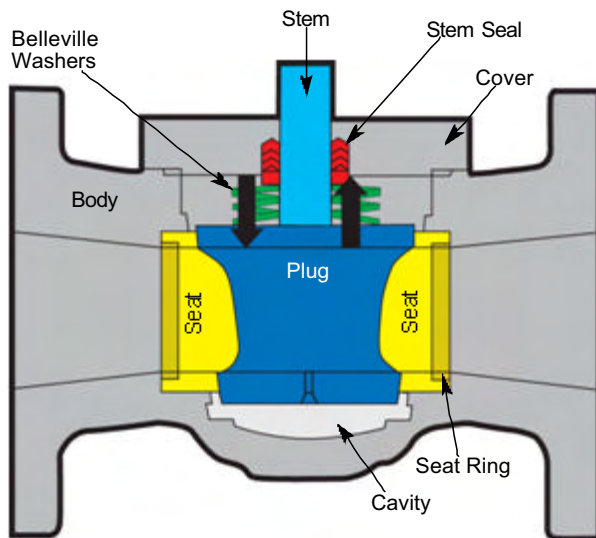



### **Top Entry Design Allows Ease of Maintenance**

Top entry design allows periodic maintenance to be performed with minimum downtime required for disassembly and reassembly. Top entry design also means the seats can be replaced without removing the valve from the line. Using common hand tools, worn seats can be removed and new seats inserted in as little as ten minutes.

### **Self-Aligning Double Seat Seals Both Ports Simultaneously**

The tapered plug design provides automatic self-alignment of the two separate seats. The unique seat design, combined with the self-adjusting plug, seals both ports at the same time and provides bi-directional shutoff to full ANSI ratings.

### **High Flow Capacity Minimizes Turbulence**

Straight-through flow and a large port minimize turbulence and pressure loss.

### **Variety of Body and Plug Materials Available**

A choice of body and plug materials includes: 316 stainless steel, carbon steel, Alloy 20, Monel and Hastelloy C. For economy and corrosion resistance, a nickel plated ductile iron plug is available. Other body and plug materials available on request, including Inconel.

### **Variety of Seat Materials Available for Multiple Applications**

Seat options meet a wide range of application requirements. Seat materials include PTFE, reinforced PTFE and UHMW (ultra high molecular weight) polyethylene, all of which provide drip-tight shutoff. A carbon graphite seat provides ANSI Class IV shutoff for high temperature applications. Seat materials are engineered to application requirements for temperatures to 1000°F (540°C).  
(See pressure/temperature capability curves for limitations.)



### Variety of Body Designs and End Connections

The Permaseal® design offers a variety of models including two-way and three-way flow patterns; partial, full and bolt-on jackets; double block and bleed; and flush-through valves. Modified construction is also available for chlorine service. A bleed hole to vent the body cavity is located on the upstream side of the plug, when in the closed position. End connection options include threaded, flanged, socket weld and butt weld. Raised face flanges are standard for all ratings and materials.

### Low Torque Allows Use of Smaller Actuators

Because the Permaseal® plug contacts only the seats and not the body walls, torque is much less than a sleeved or lined valve. The lower torque allows the use of smaller, less expensive actuators.

### Actuator Flexibility Options

Permaseal® Plug Valves are available with a variety of actuator options including levers, handwheels, spring diaphragm, Compak double-acting and spring return cylinders, or electric motors. All actuator top mounting pads/adaptor brackets are compatible with the ISO-5211/1 standard, making actuators interchangeable with other rotary control valves.



### Accessories

Permaseal® valves can be furnished with a variety of special accessories and options to meet specific application requirements. Accessories available include air filter regulators, solenoid valves, mechanical or proximity switches, potentiometers and position transmitters.



### 3-Way Valves

Three-way valves are designed for shutoff or control on mixing and diverting services. Permaseal® three-way valves are available in 0.5–6" (5–150mm) sizes with flanged or butt weld ends, and in 0.5–2" (15–50mm) sizes with screwed or socket weld ends. Three-way valves are similar to standard two port models except with a third port on the bottom of the body. A variety of plug designs and 90° or 180° rotation allow flow arrangements as shown. Refer to Permaseal® technical bulletin for details.

# Fugitive Emissions Construction

## Secondary Packing Chamber Provides Versatile Sensing Port

Permaseal® Plug Valves are available with a secondary packing chamber. In addition to the redundancy of dual stem seals and the advantages they provide, the secondary chamber also provides a sensing port that can be used to:

- Contain emissions and detect with an analyzer.
- Detect pressure changes as indication of leakage.
- Pump sealants into the lantern ring area to effectively seal a leak in the primary packing.
- Pressurize the chamber with inert gas to balance system pressure.
- Vent emissions to flare stack.

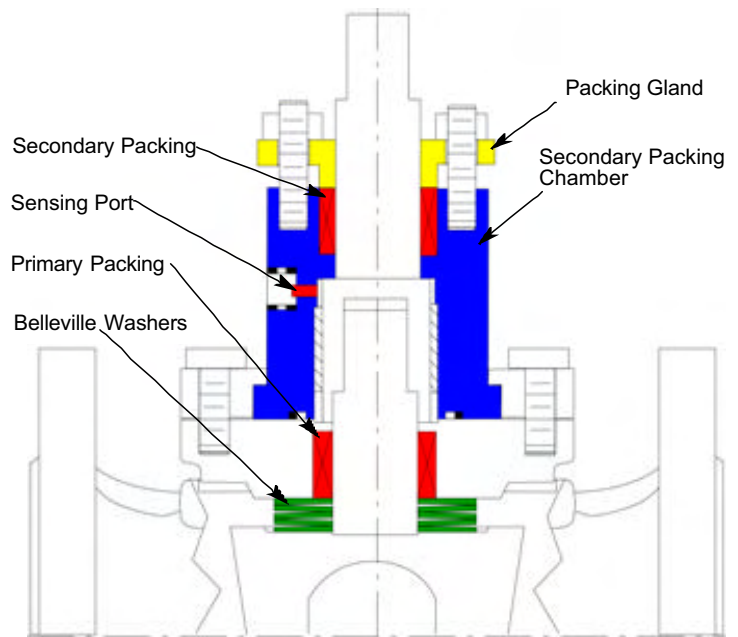

Permaseal Plug Valve

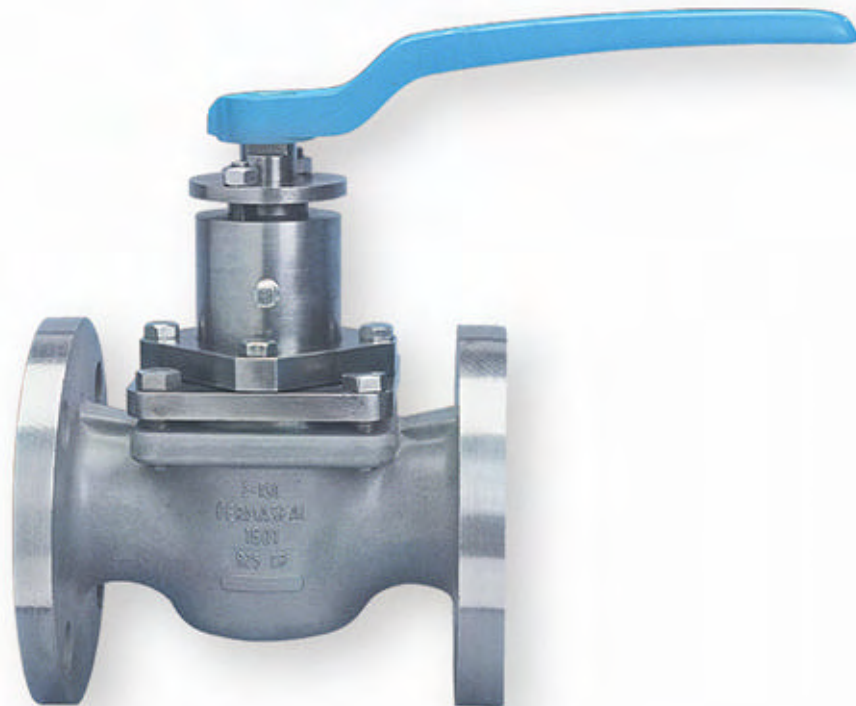

## Jacketed Valves

Permaseal® Plug Valves can be specified with partial, full or bolt-on jackets. The inherent features of Permaseal® valves combined with a jacketed design make them ideal for piping systems where continuous process flow is required. Jackets allow application of heat to the valve to maintain higher and more precise control of the process temperature, preventing build-up or solidification in the system. All jackets are rated at 150 psi (1030 kPa) at temperatures to 750°F (400°C).

### Full Jackets

Fully jacketed valves provide the fastest and most uniform transfer of heat to assure flow through the valve for critical processes. The jacket encompasses the complete valve body including contact with the oversized valve flanges. Face-to-face dimensions conform to ANSI standards for the flange size. The jackets are available on 0.75–2" (20–50mm) and 3–6" (80–150mm) valves. Carbon steel valves have carbon steel jackets and 316 stainless steel/high alloy valves have 304 stainless steel jackets. Threaded NPT couplings are used to pipe the heating medium.



### Partial Jackets

Partial jackets are the most economical, allowing use of standard flanges and providing heat transfer to the body of the valve. They are designed to assure valve operation on non-critical processes. Jackets are available on 2-way valves in 0.5–6" (15–150mm) sizes. Carbon steel jacket material is used on carbon steel valves and 304 stainless steel jacket material is used with 316 stainless steel and high alloy body materials. The heating medium is piped through threaded NPT couplings.

### Bolt-On Jackets

This versatile jacket bolts in place for converting standard valves to fully jacketed models. Uniform flange-to-flange heating of the valve is provided at continuous temperatures to 750°F (400°C) at a pressure rating up to 150 psi (1030 kPa) with no danger of cross contamination of the process. The heating medium enters the carbon steel heat exchanger embedded in the aluminum alloy jacket casting. Heat is transferred to the valve with the aid of a heat transfer media applied at installation. Bolt-on jackets are available on 2-way 1–6" (25–150mm) valve sizes with 150 lb. end connections.



## Permaseal® Automatic Well Test Valves

Permaseal® Automatic Well Test Valves allow samples of crude oil mixed with sand and traces of steam to be automatically sampled from well heads. Permaseal® Plug Valves are proven performers in hot, corrosive and abrasive oil production service. Since accurate well testing is an essential part of maximizing the profitability of oil fields, a leaky valve within a manifold may compromise the accuracy of all individual well tests, leading to lost production. The Permaseal® Plug Valve's ability to demonstrate dependable and reliable positive shutoff gives production engineers the information needed to maximize well pumping efficiency. A variety of Well Test Valve configurations are available including 3-way valves, double block and bleed, and dual Permaseal® valves with one common actuator.

### 3-Way Well Test Valves

Permaseal® 3-Way Plug Valves allow flow to be diverted to the third port for sample collection.



### Double Block and Bleed

When fitted with a NPT tap and bleed valve at the annulus of the valve body, the Permaseal® Plug Valve has the advantage of being quickly and easily checked in service for leakage. And, the top entry design makes it easy to repair if necessary.

### Dual Permaseal® Valves With Common Actuator

The two-valve, one actuator Permaseal® AWT Assembly installed in a single well manifold allows oil lease personnel to easily determine if cross contamination is occurring between wells. The double block and bleed design prevents cross-contamination and ensures that test results reflect the true composition of crude oil from an individual well.

### Well Test Block Valve

When a reliable block valve is needed to check the system for leakage, a Permaseal® Plug Valve can be installed downstream of the control valve. A bleed tee can be installed in the pipeline to check for leakage of an upstream control valve.

### NACE Compliance

As an option, Automatic Well Test Valves can be supplied to meet the requirements of NACE standard MR-01-75.

## **Sales and Service**

SOUTHERN MANUFACTURING representatives are located in major cities throughout the world.  
For the name of the representative nearest you, contact:

**Web Site: [www.smg-global.com](http://www.smg-global.com) E-Mail: [sales@smg-global.com](mailto:sales@smg-global.com)**

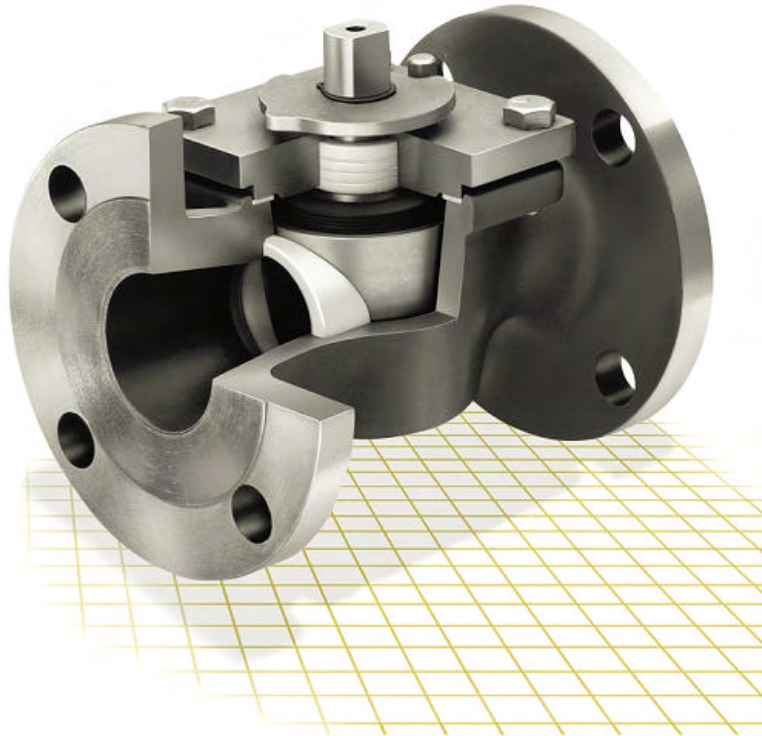

**SMG VALVES** a Unit of Southern Manufacturing Group, Inc.

## **PermaSeal® Plug Valves**

7693 Manchester Hwy.  
Morrison, TN 37357  
Phone: (931) 668-5377  
Fax: (931) 668-5378  
Email: [sales@smg-global.com](mailto:sales@smg-global.com)  
Web: [www.smg-global.com](http://www.smg-global.com)

SOUTHERN MANUFACTURING GROUP, INC. reserves the right to incorporate our latest design and material changes without notice or obligation. Design features, materials of construction and dimensional data, as described in this bulletin, are provided for your information only and should not be relied upon unless confirmed in writing by SOUTHERN MANUFACTURING GROUP, INC. Certified drawings are available upon request.

